

Severe™ V Series



**6 or 12 Volt Nema-4X Emergency Battery Unit
Sealed Maintenance-Free Lead-Calcium or Nickel
Cadmium Battery**

UL Listed

**UL Listed for wet and damp locations
(-40°C to +40°C) (-40°F to +104°F)**

The Severe™ V Series was designed for use in commercial as well as industrial heavy-duty environments, such as hose-down areas, food-processing facilities, parking garages as well as harsh environments. This battery unit will deliver unsurpassed pathway illumination – up to 70 feet center-to-center with 2-20 Watt MR16-IR lamps.

FEATURES

Reliability

The Severe™ V Series battery unit has a three-year full warranty (excluding lamps and fuses).

Unit Data

The equipment is constructed of a fully gasketed die-cast aluminum back plate and an equipment frame of industrial grade thermoplastic with a gasket around the lens and canopy, specifically designed for harsh environments. The front of the unit is protected by a clear, heavy-duty, vandal-resistant UV stabilized polycarbonate, fixed with tamper-proof screws. Each battery unit comes standard with non-audible improved diagnostic charger board, 15 minute time delay and lamp disconnect as well as tamper-proof screws and bit. The housings are available in three colors, mist-white, black or gray. The standard unit can be wall mounted on a 4-inch junction box, although a universal bracket is available as an accessory for mounting on poles, beams or strut metal framing. Units with Nickel-Cadmium batteries are listed for damp and wet locations (+10°C to +40°C/+50°F to +104°F). Available as a remote fixture, refer to Severe ELF650 Series in the Remote Fixtures section.

Light Source

Fully field adjustable lamp head assembly offers the choice of MR16 halogen lamps up to 12V, 20W-IR or high-efficiency, 5-watt, MR16 LED lamps. The unit supplies 90 minutes of emergency operation.

Charger

The Severe V Series Emergency Battery Unit is equipped with a fully automatic Improved Diagnostic Micro-controller based circuitry. The Micro-controller tests, detects and indicates any malfunction or failure of the battery, charger circuitry, or lamps. An external LED signals a general service alarm, while four internal diagnostic LED's indicate the nature of failure. The board is factory preset to non-audible diagnostic and a 15 minutes time delay. These functions can be enabled or disabled during installation. The equipment comes standard with a dual voltage input of 120/277Vac.

OPTIONS

(Add Suffix to Model No.)

Suffix

Cold Weather Location (-40°C to +40°C) (-40°F to +104°F).....**CW4 ***

*Available on 2V12G1 (24W) and 2V12G2 (36W) Lead-Calcium Battery Unit Only.

ACCESSORIES

(Order as a separate item)

Additional Special Bit for Tamper-proof Screws.....**TPB**

Universal Bracket for Mounting on Poles,

I-Beams or Superstrut® Structures.....**PMK**



POWER CONSUMPTION CHART

AC Specification			
Unit Type	Voltage	Current (Max.)	Effective Power
Standard	120/277Vac, 60Hz	0.2/0.11 A	Less than 20W
Cold weather (option)	120/277Vac, 60Hz	0.7/0.35 A	Less than 100W

UNIT RATING CHART

Furnished standard with two 9 watt High Intensity Incandescent lamps.

UNIT EQUIPMENT - WITH REMOTE CAPABILITY				
Sealed Maintenance-Free Battery Types	*Watts to 87-1/2% of Rated Battery Voltage			
	1-1/2 Hrs.	2 Hrs.	3 Hrs.	4 Hrs.
Lead-Calcium	18	12	-	-
	24	16	12	-
	36	24	20	14
	54	36	27	20
Nickel-Cadmium**	24	18	12	-

*National Electrical Code Specification

**Listed for Wet and Damp Location

DIMENSIONS

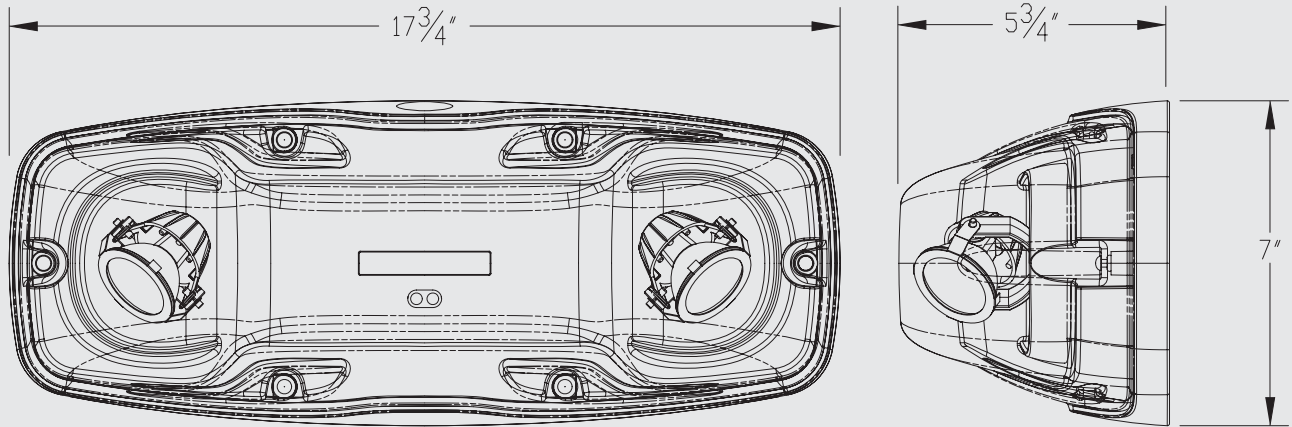

Dimensions are approximate and subject to change

UNIVERSAL MOUNTING BRACKETS

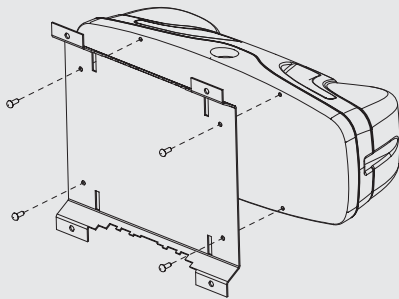

PMK KIT (screws included)

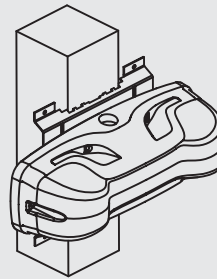

Beam Mounting

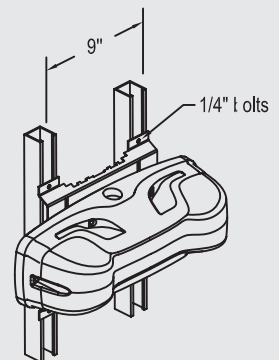

Superstrut Mounting

ORDERING FORMAT

2	V12G2	/M12	-B	-D	
# of Heads	Series	Lamps	Color	Charger	Options
2= 2 heads	VG1= 6V-18W, Lead-Calcium V12G1= 12V-24W, Lead-Calcium V12N1= 12V-24W, Nickel-Cadmium V12G2= 12V-36W, Lead-Calcium V12G3= 12V-54W, Lead-Calcium	/L5= LED 12V-5W /M6= 6V-6W, MR16 /M12= 12V-12W, MR16 /MH20= 12V-20W, MR16-IR	-B= Black -G= Gray -M= White	-D= Improved Diagnostic Non-Audible (Standard) -DA= Improved Diagnostic Audible	Blank = No Options -CW4 = Cold Weather* (-40°C to +40°C) *Only Available with V12G1 & V12G2.