



AC LED WALL PACK



WARNING:
Risk of Shock.
Disconnect Power before Installation.
Cap all unused wires.



IMPORTANT SAFEGUARDS

When using electrical equipment, basic safety precautions should always be followed including the following:

READ AND FOLLOW ALL SAFETY INSTRUCTIONS

1. All servicing should be performed by qualified service personnel.
2. All electrical connections must be in accordance with local codes, ordinances and the National Electric code.
3. Do not let power supply cords touch heated surfaces.
4. Do not mount in hazardous locations.
5. Do not mount near gas or electric heaters.
6. Equipment should be mounted in locations and at heights where it will not readily be subjected to tampering by unauthorized personnel.
7. The use of accessory equipment not recommended by the manufacturer may cause an unsafe condition.
8. Do not use this equipment for other than intended use.

SAVE THESE INSTRUCTIONS

i

IMPORTANT: Install product no higher than the maximum mounting height of 10 feet from the floor.

Installation Instructions

Turn off AC power.

Wall Mount

1. Using a flat head screwdriver, insert the blade into the two slots and rotate to remove the back plate (see figure 2).
2. Remove the appropriate knockouts in the back plate (see figure 3).
3. Feed wires through the center hole of the back plate.
4. Mount and secure the back plate to the junction box (see figure 4).
5. Make the proper connections (see figure 5 & 6): This unit can accept voltages of 120 - 277Vac. Connect the white wire (neutral) and the black wire (120-277Vac) to the building power supply.
6. Feed wires back into the junction box.
7. Snap the front cover onto the back plate.
8. Restore power.

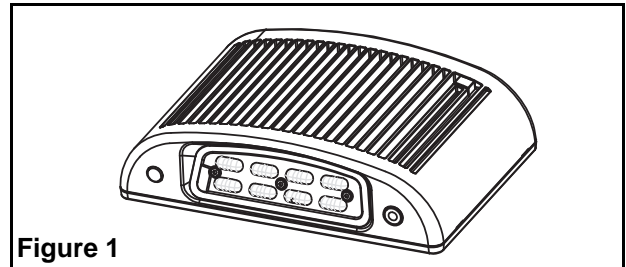

Figure 1

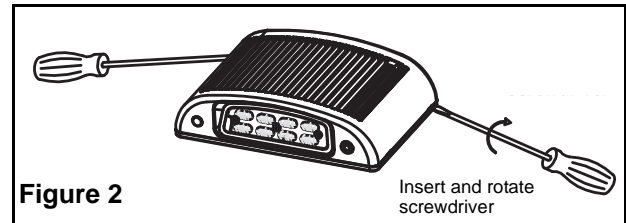

Figure 2

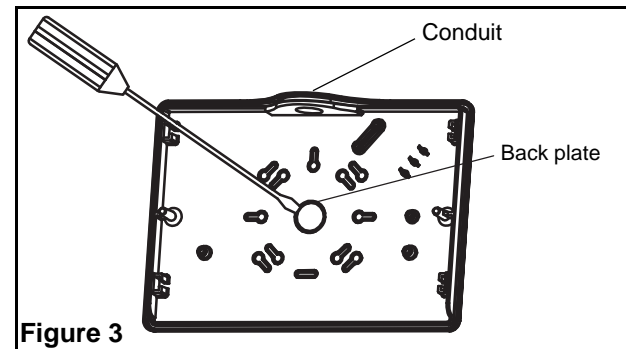

Figure 3

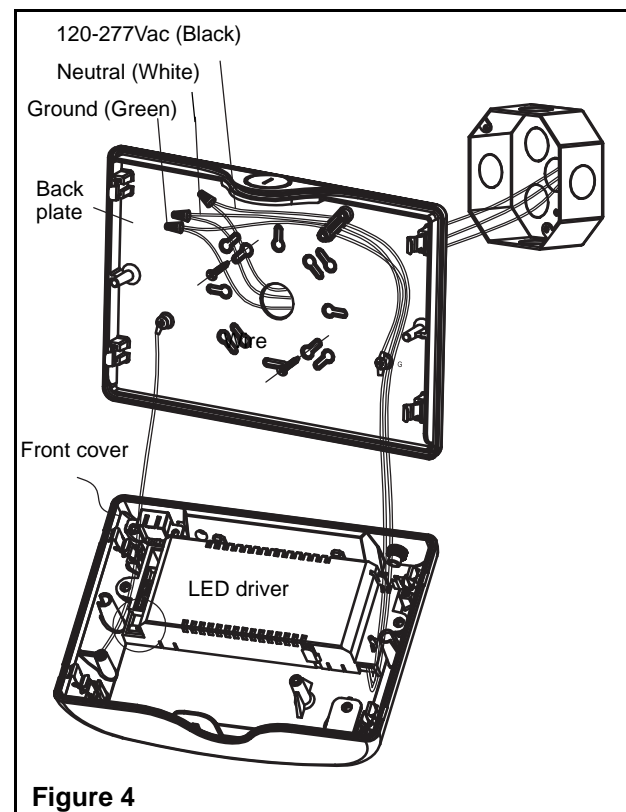

Figure 4

Conduit Mounting

1. Open front cover and remove the 1/2 inch NPT plug on the top flange of the fixture (see figure 1 and 4).
2. Secure conduit to 1/2 inch NPT hole and feed wires into the fixture.
3. Refer to section 5 - 8 above to complete the installation.

Photosensor

This unit comes preset with a photosensor. To control the unit from a wall switch the photosensor will need to be deactivated and wired according to figure 6.

This unit comes with a (3) three year limited warranty.

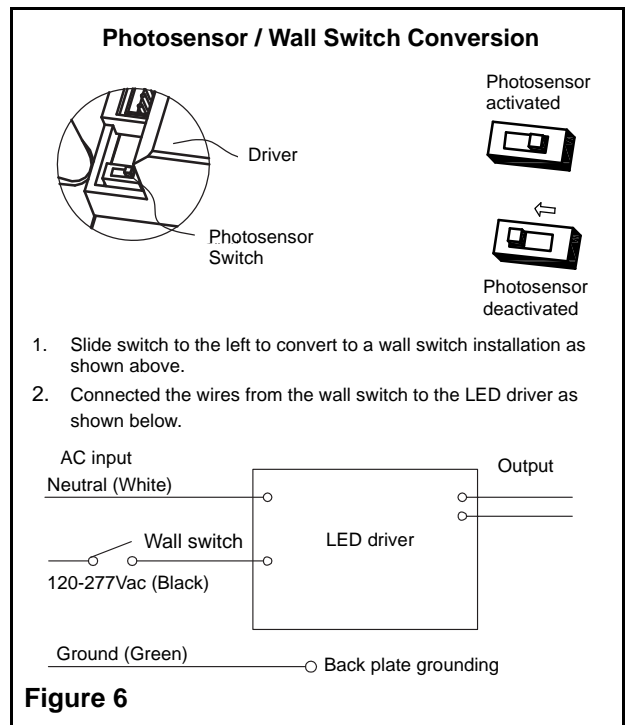
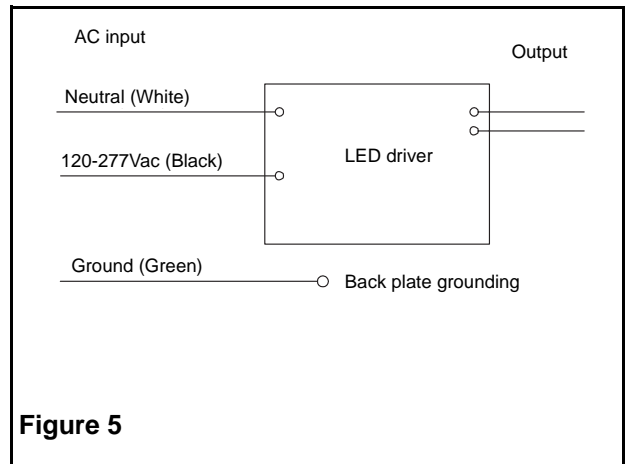

LED EMERGENCY PACK



WARNING:
Risk of Shock.
Disconnect Power before Installation.
Cap all unused wires.



IMPORTANT SAFEGUARDS

When using electrical equipment, basic safety precautions should always be followed including the following:

READ AND FOLLOW ALL SAFETY INSTRUCTIONS

1. All servicing should be performed by qualified service personnel.
2. All electrical connections must be in accordance with local codes, ordinances and the National Electric code.
3. Do not let power supply cords touch heated surfaces.
4. Do not mount in hazardous locations.
5. Do not mount near gas or electric heaters.
6. Use caution when handling batteries.
7. Avoid possible shorting.
8. Equipment should be mounted in locations and at heights where it will not readily be subjected to tampering by unauthorized personnel.
9. The use of accessory equipment not recommended by the manufacturer may cause an unsafe condition.
10. Do not use this equipment for other than intended use.
11. Allow battery to charge for 24 hours before first use.

SAVE THESE INSTRUCTIONS



IMPORTANT: Install product no higher than the maximum mounting height of 10 feet from the floor.

Installation Instructions

Turn off AC power.

Wall Mount

1. Using a flat head screwdriver, insert the blade into the two slots and rotate to remove the back plate (see figure 2).
2. Remove the appropriate knockouts in the back plate (see figure 3).
3. Feed wires through the center hole of the back plate.
4. Mount and secure the back plate to the junction box (see figure 4).
5. Make the proper connections (see figures 5 & 6): This unit can accept voltages of 120 - 277Vac. Connect the white wire (neutral) and the black wire (120-277Vac) to the building power supply.
6. Feed wires back into the junction box.
7. Connect the battery connectors to the PCBA (see figure 4).
8. Snap the front cover onto the back plate.
9. Restore power and press the test button. LED heads will turn on.

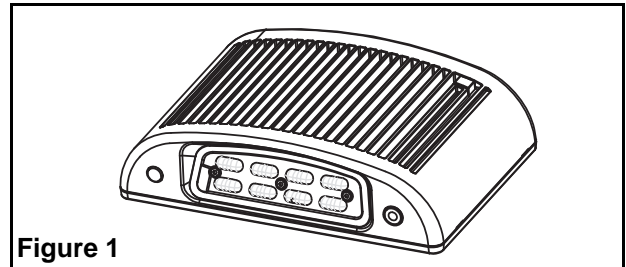

Figure 1

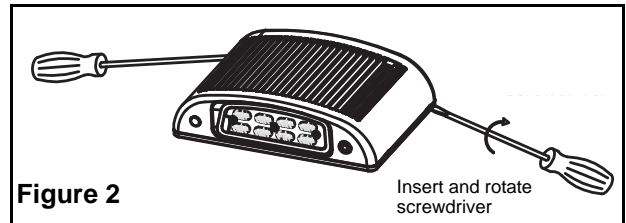

Figure 2

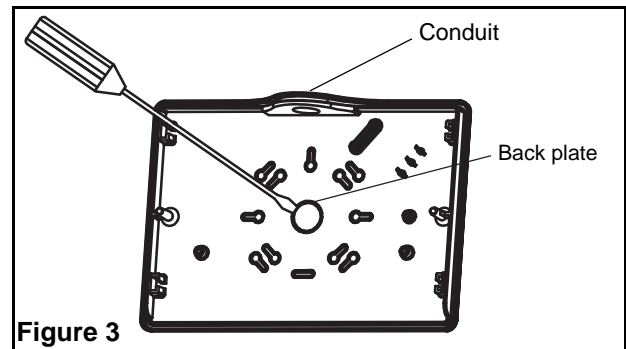

Figure 3

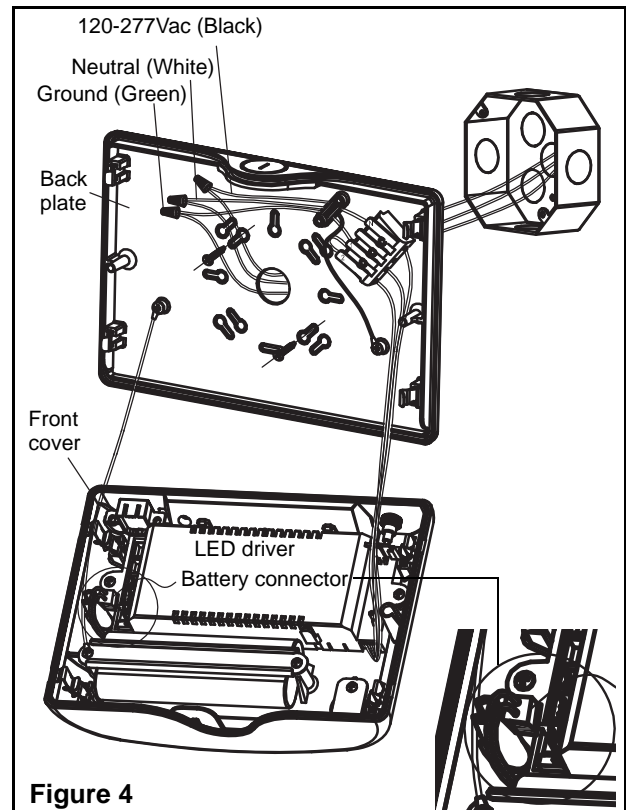

Figure 4

Conduit Mounting

1. Open front cover and remove the 1/2 inch NPT plug on the top flange of the fixture (see figure 3).
2. Secure conduit to 1/2 inch NPT hole and feed wires into the fixture.
3. Refer to section 5 - 9 above to complete the installation.

Photosensor

This unit comes preset with a photosensor. To control the unit from a wall switch the photosensor will need to be deactivated and wired according to figure 6.

Heater Pad Wiring

120Vac: Prewired at factory.
277Vac: Remove the blue wire from the terminal block. Remove the wire nut connecting the black and red wires. Using the wire nut connect the blue and red wires. Cap the black (see fig. 7).

Manual Testing

Press test switch, the pilot light will turn off and LED heads will turn on. Release test switch, pilot light will turn on and the LED heads will turn off.

Maintenance

None required. Replace the batteries as needed according to ambient conditions. Equipment must be tested regularly in accordance with local codes.

Trouble shooting guide

If LED heads or LED indicator does not illuminate, check the following:

1. Check AC supply.
2. Unit has shorted or battery is not connected.
3. Battery discharge. Connect unit to AC supply and allow battery to charge for 24 hours before re-testing.
4. If above trouble shooting hints do not solve your problem, contact factory for assistance.

This unit comes with a (3) three year limited warranty.

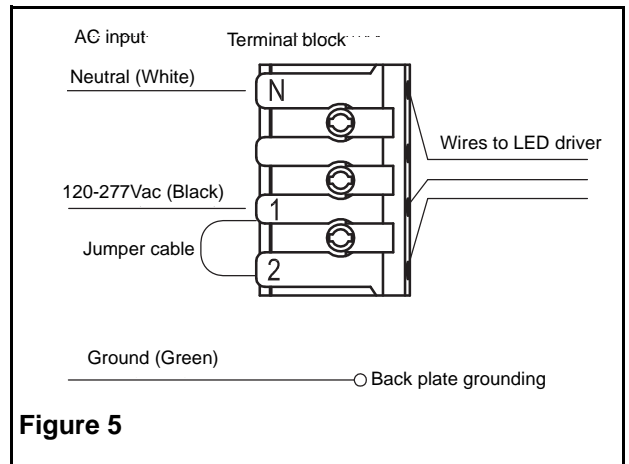

Figure 5

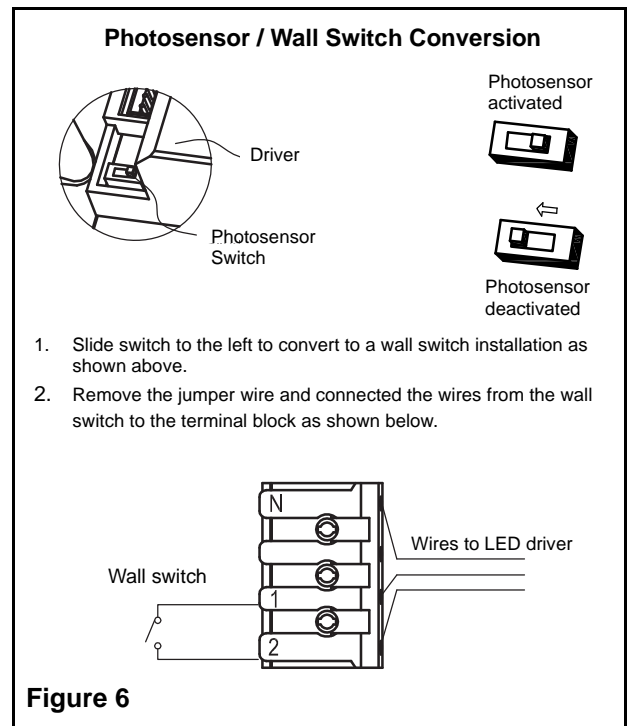

Figure 6

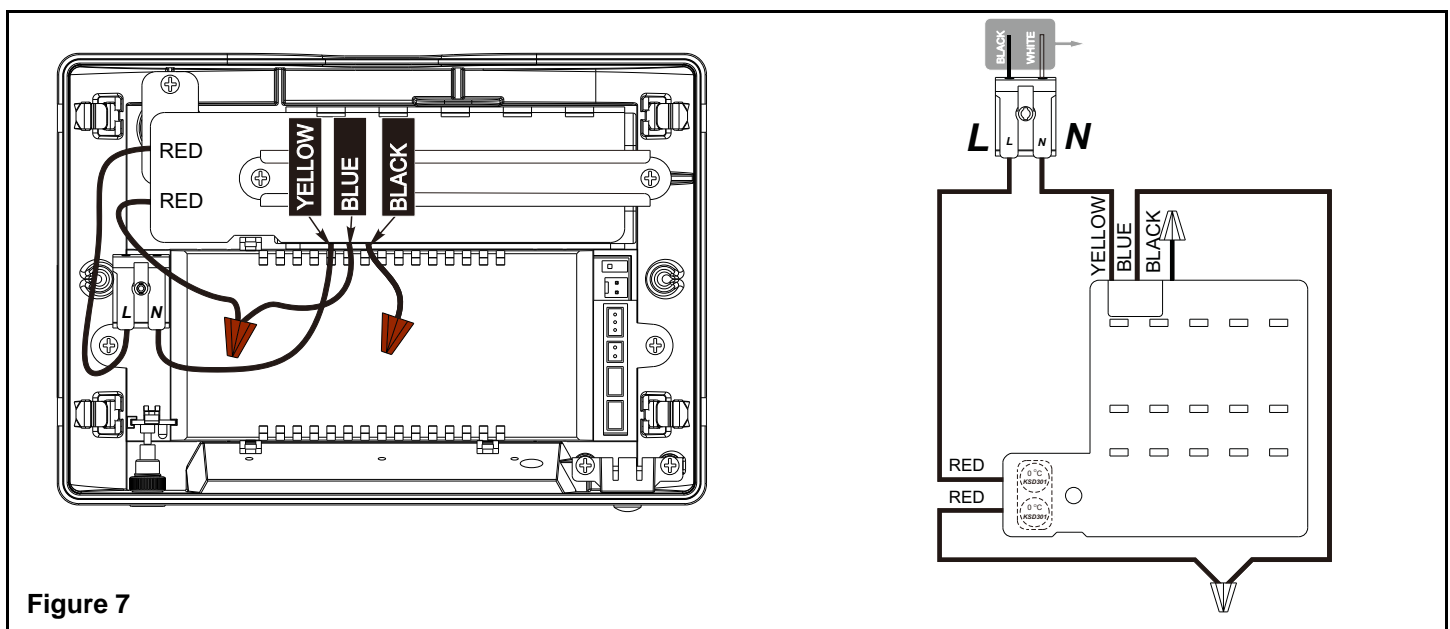

Figure 7