

LS605P1 Series

6 Volt Recessed Down Light



Housing

- Low profile polycarbonate white trim
- Fully recessed steel backbox

Mounting

- Ceiling or wall recessed mount

Electronics

- Pulse plus charger
- Low voltage disconnect
- Automatic brownout protection
- Battery lock-out
- Fused output circuit
- 120/277 60Hz

Dimensions (Dimensions are approximate and subject to change)

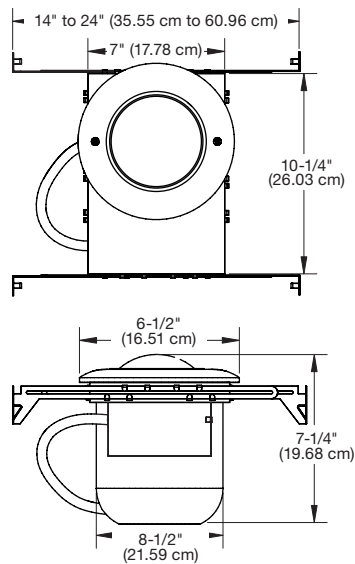

Choice of Sealed Maintenance-Free Battery

- 6V Lead-Calcium battery

Approval

UL 924 Listed

Warranty (subject to proper installation and maintenance)

Unit: three-year limited warranty

Detailed warranty terms located on [page 182](#) or online at: www.lightalarms.com

Accessories (Order as a separate item)

Description	Product code
Remote Test Switch (metal face plate)	RTS
Remote Test Switch (plastic face plate)	RTS-1

Power consumption chart

Series	Battery	Voltage	DC Specs				AC Specs	
			Battery capacity (in watts)				Units dual voltage ¹	Current Maximum
			90 Mins	2 Hrs	3 Hrs	4 Hrs		
LS605P1/HB	Lead-calcium	6V	10	8	-	-	120VAC	0.3A

¹ Stand-by power consumption is 50% lower for lead-calcium batteries.

Ordering format

Series / Capacity	Lamp option
LS605P1= 10W lead-calcium	/HB= 6V-10W wedge-base

Example: LS605P1