

XT Series

Self-Luminous Exit Sign

Non-Electric, No Wiring or Energy Required

UL Listed

The XT Series signs are suitable for use in hazardous, explosive, corrosive, humid or any other harsh environment. The XT Series is not dependant upon the use of electrical power, either internally or externally.

FEATURES

Reliability

The "XT" Series exit signs shall be spark free and suitable for use in humid, corrosive or explosive environments. Lightalarms will replace, free of charge, any product in which the luminosity is found to be defective during its specified luminous life, or which falls below specified luminous life.

Unit Data

The XT Series Self-Luminous exit sign frame, backplate and canopy shall be of ABS molding. Tamper proof assembly with no removable fasteners. Frame finishes include white or black. The signs can be mounted flush to wall or ceiling without a canopy. The faceplate is constructed of acrylic (optional Polycarbonate) .13 inches thick. The legend is constructed of non-glare polycarbonate, .015 inches thick, open letters, field programmable arrows and background colors include red or green. Contrast ration for both conditions shall exceed .5 and meet requirements of UL924 and NFPA.

Non-Electric - These exit signs do not require batteries, lamps or electricity for illumination. Electrical wiring, power, lamp replacement and maintenance are not required.

Illumination is provided by phosphor-coated borosilicate tubes filled with tritium gas. Tritium gas energizes the phosphor-coated tubes in the sign. The low energy beta emission of tritium striking the phosphor coating inside the pyrex® glass tubes causes illumination to be generated.

Harsh and/or Hazardous Environments

- Mines
- Refineries
- Paper Mills
- Food Processing Plants
- Spray Booth Areas
- Off Shore Rigs
- Chemical Plants
- Grain Elevators

Licenses and Codes

- UL - Underwriters Laboratories
- OSHA - Occupational Safety and Health Administration
- BOCA, ICBO, SBCCI - American Building Officials
- MSHA - Mine Safety and Health Administration
- NRC - Nuclear Regulatory Commission
- Uniform, Basic and Standard Building Codes

Meets full test specifications of ANSI (American National Standards Institute) for use in harsh or dangerous environments, Meets requirements of National Electrical Codes, Class I and II.

Power Requirements

120/277 Vac, 60Hz, 0.3/0.15 Amp

OPTIONS

(Add Suffix to Model No.)

Aluminum Frame	-AF
Fully Recessed Frame.....	-FR
Aluminum Frame and Polycarbonate shield.....	-AFPC

ACCESSORIES

(Order as a separate item)

White Pendant.....	PW-*
Black Pendant.....	PB-*

*Specify length of pendant (12", 24", 36" etc.)



DIMENSIONS

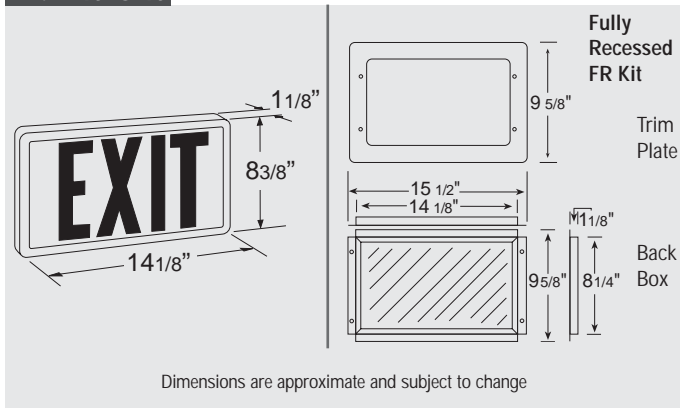

MOUNTING

Single Face Signs

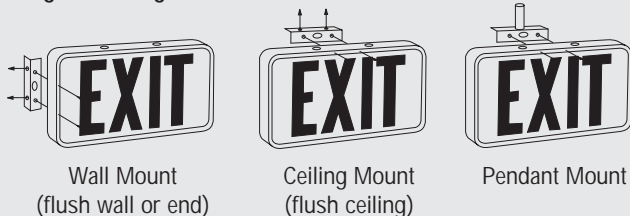

Double Face Signs

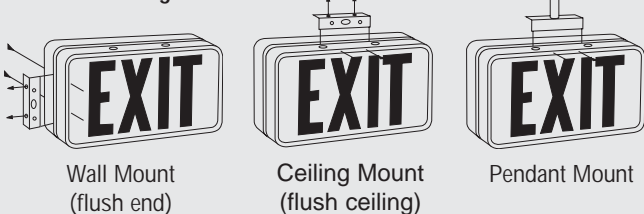

ORDERING FORMAT

XT	10	B	R	-FR
Series	Sign	Housing	Legend	Options
XT=Single	Life	Color	Color	-FR=Fully Recessed Frame
Face	10=10 Years	W=White	R=Red	
2XT=Double	15=15 Years	B=Black	G=Green	
Face	20= 20 Years			