

## RSTH Decorative Series

### 6 Volt Self-Powered Recessed Down Light Maintenance-Free, Long Life Nickel-Cadmium Battery Evaluated to UL 924 Standard

The RSTH Decorative Series integrates contemporary design elements with the latest in high-tech emergency lighting capabilities. This self-powered down light brings architects, designers and engineers a sleek, refreshing new take on emergency lighting solutions. Designed with clean, classic lines and available in a range of colors and tones to compliment any commercial or high-end interior where taste is a factor.

#### FEATURES

##### Reliability

The RSTH Decorative Series has a three-year full warranty (excluding lamps and fuses).

##### Unit Data

This internally self-powered recessed down light is constructed of a durable powder coated, die cast aluminum and uses a MR16 lamp source powered by a sealed Nickel-Cadmium battery. The RSTH is furnished with a metal, fully recessed back box to house the electronics, battery and wiring. The duration of operation provided by the Nickel-Cadmium battery is 90 minutes minimum, as required by NFPA101 Life Safety Code. Standard finish is white, but also available in black, brushed nickel, chrome and polished brass. Adjustable hanger bars are supplied with each unit.

##### Lamp

Furnished with one 6 volt, 6 watts MR16 halogen lamp. The Light source is fully adjustable by rotating the gimbal through 359° in azimuth and or positioning the lamp through 90° in pitch.

##### Charger

Dust tight relay automatically and instantly energizes lamp load upon failure of AC supply. Battery protection circuit automatically shuts down lamp load when battery reaches 87-1/2% of it's rated voltage. Charger is 100% solid state, includes auto-equalize, temperature compensation and is controlled by a 1% Zener reference.

##### Power Requirements

- 120V, 60 Hz, 0.046 A, 4.17W
- 277V, 60 Hz, 0.024 A, 4.76W

#### DIMENSIONS

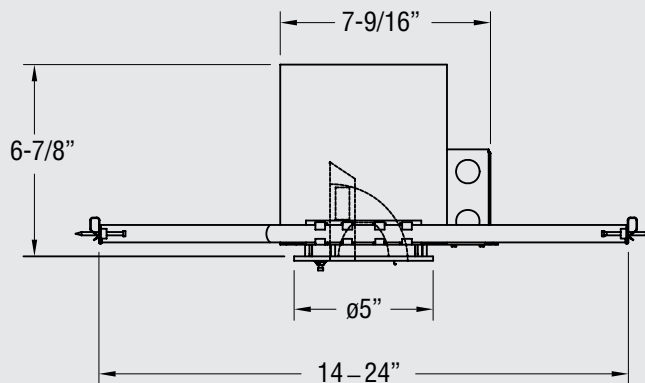

RSTH Decorative Series including back box

Dimensions are approximate and subject to change.

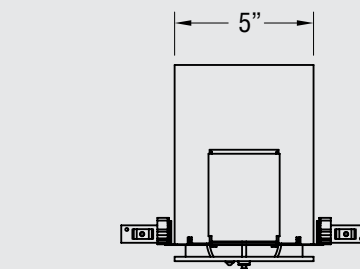

5"

5"

5"

5"

5"

#### ACCESSORIES

(Order as a separate item)

Remote Test Switch ..... PSW

#### ORDERING FORMAT

RSTH24	WH	SP	-	U
Series	Color	Emergency Back-up		Model
	WH=White	SP=Self-Powered		-U=USA model
	BK=Black			
	BN=Brushed Nickel			
	CH=Chrome			
	PB=Polished Brass			

Replacement lamp number: 580.0074-L 6V 6W