



605P1 Series

**6 Volt Decorative Recessed Gimbal
Maintenance-Free, Lead-Calcium, Long Life
Lead or Nickel-Cadmium Battery
UL Listed**

The **605P1 Series**, a classic top-hat style unit with gimbal mounted lamp, fully recesses into ceiling with only the lens and trim visible. Ideal for low ceilings and blends inconspicuously with existing recessed lighting schemes.

FEATURES

Reliability

The 605P1 Series has a three-year full warranty (excluding lamps).

Unit Data

All components are contained in drawn steel box. The upper side of the recessed steel housing contains the battery and charger. The lower portion of the housing will contain an 8 watt halogen lamp with a horizontal rotation of 358° and vertical angle adjustable to ±42°. Standard finish of trim is mist-white plastic. NYC approved version will include a metal trim and gimbal assembly, also finished in mist-white. The LED pilot light and test switch are located on the side of the lamp ring.

The 605P1 Series comes standard with a slide out chassis and two quick-connect plugs to make installation and servicing easy. Adjustable hanger bars are supplied with each unit.

Lamp

Furnished with one 6 volt, 8 watt high intensity halogen lamp.

PulseType Charger

- Automatic, temperature compensated, pulse type charger.
- High capacity, automatic, dust-tight instantaneous transfer relay.
- Low voltage disconnect prevents overdischarge of battery. Automatic brownout protection is provided.
- Labor saving AC line latch prevents battery discharge during installation to a non-energized circuit.
- Fused output circuit.

Controls

- Combination AC-ON/charge monitor LED
- Momentary test switch allows for quick operational check of entire system.

Power Requirements

120/277Vac, 60Hz, 0.3/0.15 Amp

OPTIONS

(Add Suffix to Model No.)	Suffix
Black Housing and Gimbal	-B
NYC Approved Version	-M*
*Includes metal trim and gimbal assembly.	

ACCESSORIES

(Order as a separate item)

Remote Test Switch	PSW
--------------------------	-----

ORDERING FORMAT

605	P1	/LH5	-R	-M
Series	Battery Type Capacity (see chart)	Lamp Suffix	Recessed	Option (NYC Approved)

DIMENSIONS

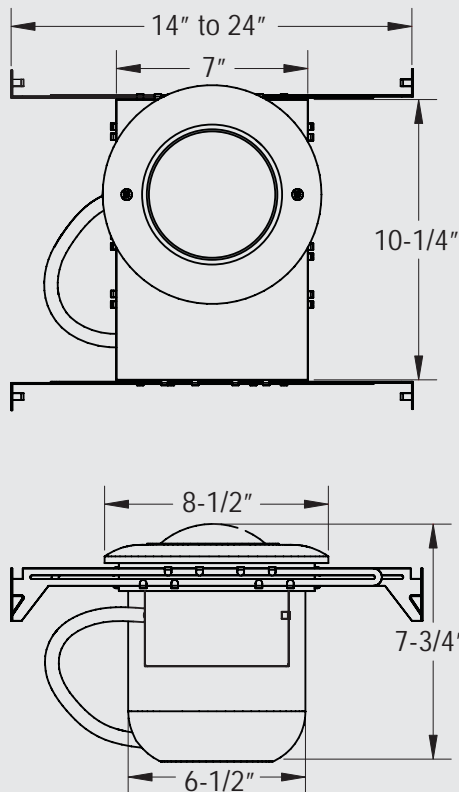

Dimensions are approximate and subject to change.

UNIT RATING CHART

NO REMOTE CAPABILITY						
Volts	Model # (Unit/Lamp Suffix)	Battery Type	*Watts to 87-1/2% of Rated Battery Voltage			
			1-1/2 Hrs.	2 Hrs.	3 Hrs.	4 Hrs.
6	605P1/LH5-R	Lead-Calcium	9	—	—	—
6	605E1/LH5-R	Long-Life Lead	9	—	—	—
WITH REMOTE CAPABILITY						
6	605C1/LH5-R	Nickel-Calcium	18	12	9	—
6	605E2/LH5-R	Long-Life Lead	18	11	8	—

* National Electrical Code Specification