

Wire Guard

CATALOG NUMBER WG1

Application

Series DM & DS
(Top Mounted Heads);
SQ & SQ-D (Semi Recessed);
ELF644 (Surface Mount);
MG Series;
QLX500-MR (exit only-Wall Mount)

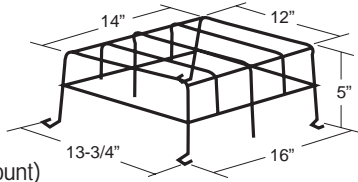

CATALOG NUMBER WG5

Application

Series XLD (AC Only ceiling & end mount);
XQ (ceiling mount); X2; X3
(ceiling & end mount) XT
(ceiling mount); X4 (Ceiling
or End Mount); QLXN500-MR
(Exit only-Ceiling or End Mount)

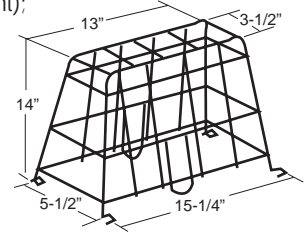

CATALOG NUMBER WG2

Application

Series PG; P12G; PN;
P12N (A Cabinet); MG; X2 & X3
(Wall mount self-powered,
no mounted head);
XLD (Wall mount)

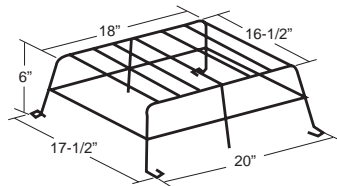

CATALOG NUMBER WG6

Application

X2; X3 (wall mount, self powered
with front mounted heads);
QLXN500R-2MR (Combo-Wall Mount)

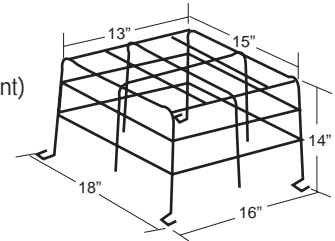

CATALOG NUMBER WG3

Application

Series PQ; P12Q;
P12N2 (B Cabinet);
SL; SN; S12E4 (C Cabinet);
EL; E12L; ECN; E12CN;
ENN; E12NN; FG; F12G

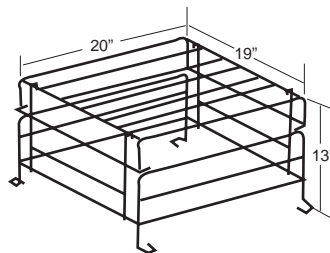

CATALOG NUMBER WG7

Application

ELF648D Remote Fixtures
(Double Heads only)

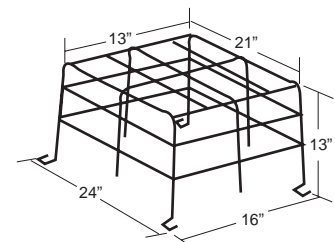

CATALOG NUMBER WG4

Application

Series DM & DS
(Side Mounted Heads Par 36);
S12E5; S12E6; S12L;
S12N; S24E; S24N; WP

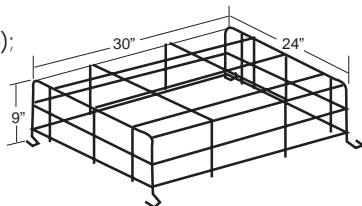

CATALOG NUMBER WG8

Application

Series ELF2; 2D; 2T (Single head);
ELF606 & 622; 622D; 622T &
645; 645D 645T & 647; 647D &
648 (Single head only).

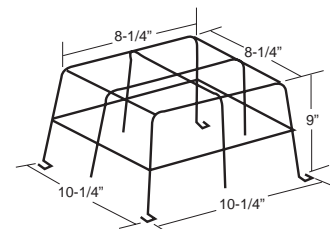

CATALOG NUMBER WG9

Application

Series ELF2; 2D (Double Head);
ELF622; 622D;
622T & 645; 645D;
645T & 648; 648D
(double head)

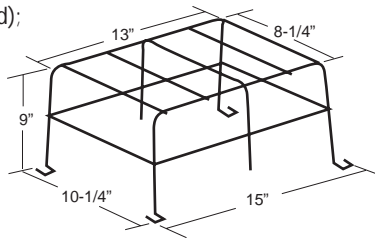

CATALOG NUMBER WG13

Application

Series IC-2; ICR-2 (Remote)
XLD (Self-powered, Wall Mount);
LCA-2MR

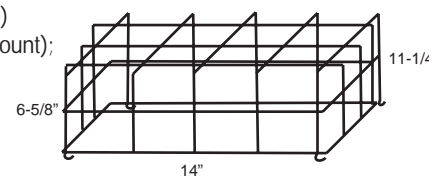

CATALOG NUMBER WG10

Application

Series DM & DS
(Side Mounted Heads, Par 18);
LCA-SQ; MG; QLXN500R-SQ
(Heads in any Position)

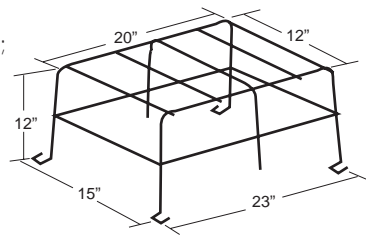

CATALOG NUMBER WG14

Application

Series XLD (Self-powered, Ceiling Mount)

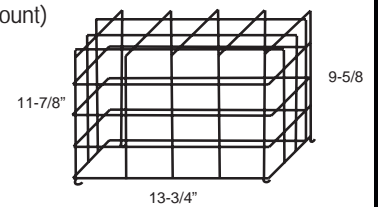

CATALOG NUMBER WG11

Application

Series 605P1; SQ & SQ-D
(fully recessed);
ELF605 & ELF644FR

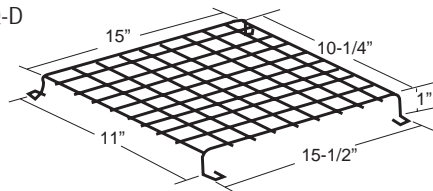

CATALOG NUMBER WG15

Application

Series XT (end mount);
XLD (self-powered, end
mount); XQ (end mount)

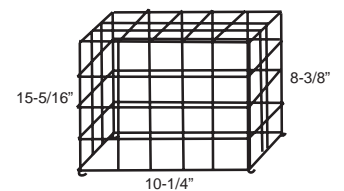

CATALOG NUMBER WG12

Application

Series XLD (AC only, wall mounted)
XQ (wall mounted); X2; X3
(AC only, wall mount); XT
(wall mount); ELF604,
ELF603 & 610; X4 (LED or
Incandescent-Wall Mount)

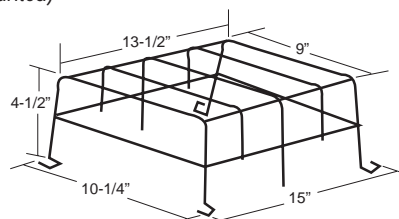

CATALOG NUMBER WG16

Application

Series Cavalier
(CA-2, CA-3 mount)

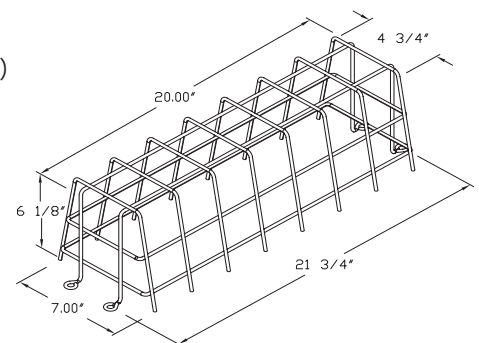

Unit Accessories

CATALOG NUMBER VRC OR VRC-4X (NEMA-4X)

Application

- DM3, DM6, DM7 Series with top mounted heads
- SQ, SQ-D Series all mountings
- X4, X2 or X3 Series LED, Incandescent (wall mounted)
AC and AC/DC or Self-Powered exit with no mounted heads
- XQ Series LED (wall mounted) AC and AC/DC or Self-Powered
- XLD, XLED Series LED, (wall mounted)

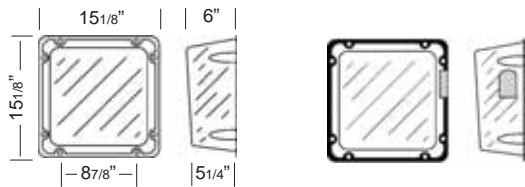

MOUNTING PLATFORMS



- 14 gauge steel
- Corrosion resistant undercoat
- Oven baked finish
- 1/2" retaining lip on three sides
- Keyhole slots for easy mounting

Model	Dimensions (inches)						
	a	b	c	d	e	f	g
MP-PQB (Mist)	17	7-3/4	12-1/4	16	3/4	5/16	5/8
MP-A (Gray)	17	7-3/4	12-1/4	16	3/4	5/16	5/8
MP-PQA (Mist)	16-3/8	5-3/4	10-1/4	12-1/2	7/8	3/16	7/16
MP12	27-1/2	7-3/4	12-1/4	16	1-5/8	5/32	5/16

Dimensions are approximate and subject to change

CATALOG NUMBER CPS OR CPS-4X (NEMA-4X)

Application

- MG Series (small cabinet) top or front mounted heads
- DM3, DM6, DM7 Series with top or side mounted heads

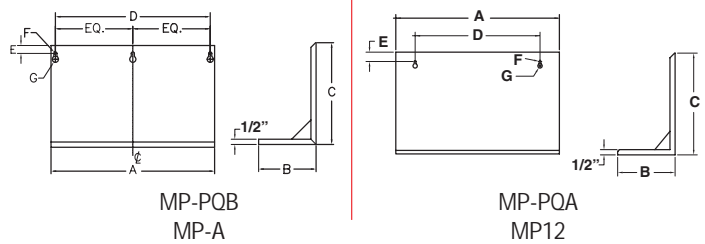
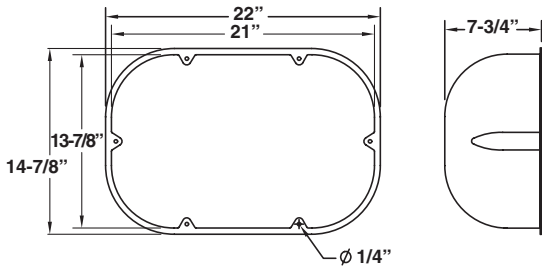

REMOTE TEST SWITCH

Make testing your ceiling mounted equipment easier with the remote test switch. Compatible with 120 or 277Vac circuits, the remote test switch will interrupt the line voltage to your equipment by means of a momentary push button switch. AC on/Charge status indicator lamp assures that power is going to your emergency lighting.

How To Order

Remote Test Switch.....PSW

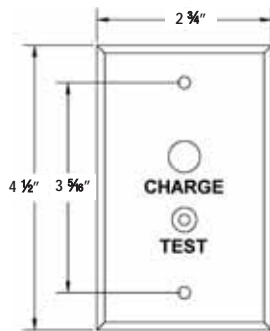

MOUNTING BRACKETS

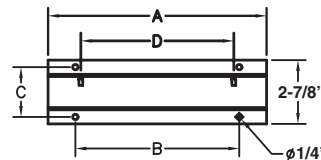

- 16 gauge steel
- Corrosion resistant undercoat
- Oven baked finish
- Supplied with rubber stand-offs for unit and machine screws to secure unit to bracket

Model	Dimensions (inches)			
	a	b	c	d
MB-A	10	7-3/4	2-3/16	7
MB-B	14-1/4	11-3/4	2-3/16	12-5/8

Dimensions are approximate and subject to change

Mounting Plate Series

Specify mounting plate designation as a suffix to fixture type model number. Plates ordered separately, specify plate designation and fixture type.

230.1238 & 230.1239

- Single, double or triple round
- Thermoplastic construction
- Mounting plates shipped with two hole plugs
- Mist or black finish only
- Mount direct to 4" octagonal box

Dimensions: 5" diameter - slotted mounting holes
3 to 3 9/16" mounting center

Off-White - 230.1238



Off-White Hole Plug - 230.1204

Black - 230.1239



Black Hole Plug - 230.1205

430.0765 & 430.0766

- Single or double round
- Aluminum construction
- Mist baked enamel finish
- Black finish optional
- Mount direct to 4" octagonal box

Dimensions: 5 1/4" diameter
3 7/16" mounting center

Standard: ELF648, ELF648D

Off-White Single - 430.0765



Off-White Double - 430.0766



450.0129 & 450.0397 & 450.0398 & 450.0398

- Single, double or triple rectangular
- Single, triple or 4-gang steel construction
- Chrome plated finish ONLY
- Mount direct to standard outlet box

Dimensions: single - 2-3/4" X 4-1/2" (for 1 fixture)
3-gang - 6-7/16" X 4-1/2" (for 2 fixture)
4-gang - 8-3/8" X 4-1/2" (for 2 or 3 fixture)
3 5/16" mounting centers all types

Standard: ELF622, ELF622D, ELF622T, ELF645T

450.0129 - No Square Hole
*450.1151 - 7/16" Square Hole
450.0194 - 1/2" Square Hole

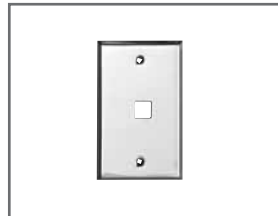

450.0397 - No Square Hole
*450.1152 - 7/16" Square Hole
450.1153 - 1/2" Square Hole

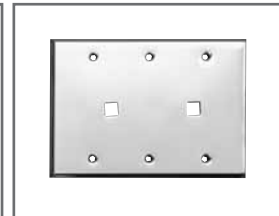

450.0398 - No Square Hole
*450.1154 - 7/16" Square Hole
450.1155 - 1/2" Square Hole

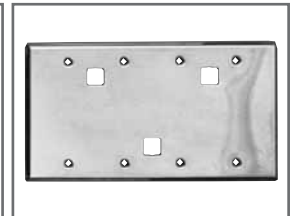

330.7583 & 330.7584

- Single or double round
- Die cast aluminum construction
- Gasketed weatherproof
- Black satin enamel finish
- Mist finish optional
- Mount direct to 4" octagonal box

Dimensions: 4-1/8" diameter
3-9/16" mounting center

Standard: ELF647, ELF647D

Off-White Single 330.7583



Black Single 330.7577

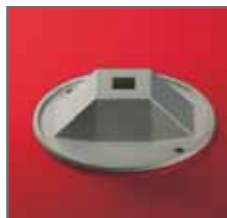

Off-White Double 330.7584



Black Double 330.7578

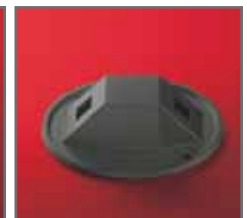

Gasket - 245.0100

12804 & 12805

- Single or double rectangular
- Die cast aluminum construction
- Gasketed weatherproof
- Silver gray enamel finish ONLY
- Mount direct to standard outlet box

Dimensions: 4-5/8" X 2-7/8"
3-1/4" mounting center

Non standard mounting plate

12804



12805

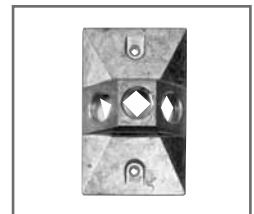

Lamp Data

HOW TO USE THIS CHART

Use the lamp chart when ordering remote lighting fixtures, non-standard lamps or replacement lamps. When ordering non-standard lamps, or lamps for remote fixtures, be sure to select lamps from those listed under the battery voltage of the unit or system powering the lamp.

Example

For a remote fixture powered by a 12 volt unit, only those lamps listed under 12 volts in the lamp chart may be used.

BE SURE TOTAL LOAD DOES NOT EXCEED THE 90 MINUTE: WATTAGE CAPACITY OF THE BATTERY, as stated in each respective unit/system selection chart.

For Unit Equipment

Replace standard lamp suffix with non-standard lamp suffix.

Example

Model 2SN2/L25 comes standard with 6 volt, 25 watt incandescent lamps. To order with 6 volt, 20 watt halogen lamps, the appropriate model number would be: 2SN2/LH8

For Replacement Lamps

Order by replacement number.

For Remote Fixtures

Include complete lamp suffix as suffix to model number.

Example

ELF645	/L9 6
Remote Fixture Model No.	Lamp Suffix

Complete Lamp Suffix must be stated (which includes voltage designation)

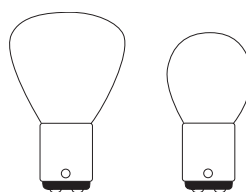
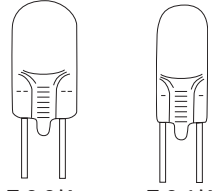
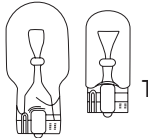
	Unit/System Battery Voltage	Watts	Rated Volts	Lamp Suffix		Replacement Number	Lamp Number	Lumens
				for Units	add Volt for Remote Fixtures			
DOUBLE CONTACT BAYONET BASE INCANDESCENT  RP-11 S-8	6 VOLT	9	6	L9	6	570.0010	135	175
		13	6	L13	6	570.0020	88	188
		18	6	L18	6	570.0037	1130	265
		25	6	L25	6	570.0038	1134	440
	12 VOLT	6	12	L6	12	570.0068	90	75
		9	12	L9	12	570.0011	138	175
		13	12	L13	12	570.0022	94	189
		18	12	L18	12	570.0030	139	360
	24 VOLT	25	12	L25	12	570.0031	1076	402
		9	24	L9	24	570.0058	304	75
		12	24	L14	24	570.0059	306	189
		18	24	L18	24	570.0060	308	264
36 VOLT	25	24	L28	24	570.0061	1638	402	
	6	36	L6	36	570.0069	1224	48	
120 VOLT	25	36	L25	36	570.0084	1054	403	
	6	120	L6	120	570.0062	6S6	41	
BI-PIN HALOGEN LAMPS  T-2 3/4 T-2 1/4	6 VOLT	10	120	L10	120	570.0063	10C7	66
		6	6	LH4	6	580.0012	784	113
		8	6	LH5	6	580.0013	785	163
		10	6	LH7	6	580.0017	787	201
		12	6	LH6	6	580.0011	786	239
		15	6	LH1	6	580.0086	JC6V 15W	300
	12 VOLT	20	6	LH8	6	580.0022	788	402
		8	12	LH8	12	580.0014	774	163
		12	12	LH3	12	580.0015	783	277
		14	12	LH9	12	580.0016	789	302
		20	12	LH2	12	580.0027	782	314
		6	6	L5	6	570.0012	939	68
WEDGE BASE INCANDESCENT  T-5 T-3 1/4	6 VOLT	7.2	6	L7	6	570.0026	927	100
		9	6	L9	6	570.0016	908	150
		9	12	L9	12	570.0025	915	138
	12 VOLT	12	12	L12	12	570.0028	912	151
		18	12	L18	12	570.0029	921	264

PAR36 SEALED BEAM LAMPS — (Available by Special Order)

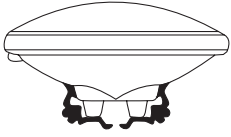
SEAL BEAM HALOGEN	Unit/System Battery Voltage	Watts	Rated Volts	Lamp Suffix/ Lamp Number	Replacement Number	Center Beam Candle Power (CP)
 PAR36	6 VOLT	HALOGEN		H7556	550.0022	400
		8	6	H7551	550.0036	550
		10	6	H7552	550.0037	650
		12	6	H7553	550.0019	850
		20	6	H7554	550.0021	1400
	12 VOLT	HALOGEN		H7555	550.0024	550
		12	12	H7557	550.0025	850
		37	12	H7616	550.0047	70,000
		50	12	H7614	550.0012	2000

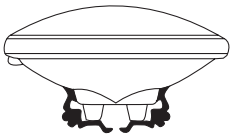
SEAL BEAM INCANDESCENT	Unit/System Battery Voltage	Watts	Rated Volts	Lamp Suffix/ Lamp Number	Replacement Number	Center Beam Candle Power (CP)
 PAR36	6 VOLT	INCANDESCENT		7613	550.0018	400
		12	6	4042	550.0030	1100
		18	6	4014	550.0016	1500
		25	6	4510	550.0017	800
		30	6	4515	550.0035	5500
	12 VOLT	INCANDESCENT		4044	550.0026	1110
		12	12	4414	550.0027	1500
		18	12	4446	550.0023	400
		25	12	4416	550.0034	35,000
		35	12	4406	550.0032	600

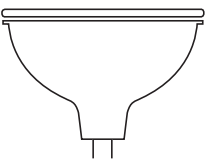
HALOGEN	Unit/System Battery Voltage	Watts	Rated Volts	Lamp Suffix		Replacement Number	Center Beam Candle Power (CP)
				for Units	add Volt for Remote Fixtures		
 MR16	6 VOLT	5	6	M5	6	580.0072	110
		6	6	M6	6	580.0074	130
		10	6	M10	6	580.0079	250
	12 VOLT	12	12	M12	12	580.0080	300
		20	12	M20	12	580.0075	600
		20-IR	12	MH20	12	580.0068	1000
		35	12	M35	12	580.0083	1300
		50	12	M50	12	580.0076	2100
	24 VOLT	12	24	M12	24	580.0070	300
		20	24	M20	24	580.0077	600
		35	24	M35	24	580.0084	1200
		50	24	M50	24	580.0078	1800

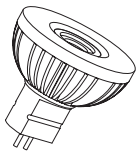
LED	Unit/System Battery Voltage	Watts	Rated Volts	Lamp Suffix	Replacement Number	Center Beam Candle Power (CP)
 MR16 SHAPE	12 VOLT LED	5*	12	L5	580.0063	205

* 3W white LED and 2W to drive engine

MSA INCANDESCENT LAMP ADAPTER
For HIT, DCBB or Bi-Pin Halogen Lamps

DC lamp plus adapter for medium Edison screw base socket. This device converts any incandescent fixture into an emergency fixture.

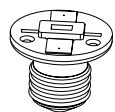
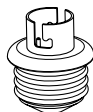
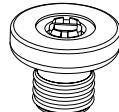
MSA Bi-Pin

MSA Double Contact

MSA Wedge Base
120 VOLT AC EXIT LAMPS

Lamp Type	Catalog	Watts	Lamp #	Base
Incandescent	570.0013	15	15T6145	Candelabra Screw Base
Incandescent	570.0024	20	20T61/2	Intermediate Screw Base
Fluorescent	595.0010	7	PL7-T4	G23

ORDERING FORMAT

MSA	-	LH5
Product Code		Lamp Symbol

Note: Lumen figures based on information supplied by lamp manufacturers, Lamp drawings shown are for shape comparison only, not actual size.

Wire Size Guide

Determining Wire Size

The following information is provided to assist in designing proper emergency lighting systems effectively and economically by using the smallest permissible wire size for load circuits. When remote lighting fixtures and/or exit signs are connected to emergency lighting units, circuit runs must be of sufficient size to maintain a proper operating voltage to all lamps. The National Electrical Code limits voltage to drop to a maximum of 5% of nominal. The table below gives the maximum length or wire run based on systems voltage, wire gauge and total wattage on the run. **To determine the maximum length of a wire run not listed**, divide the value of the load in watts into the constant listed at the bottom of each row. Example, the maximum wire run for #10 wire on a 12 volt system, with a 54 watt load, is $3397 \div 54$ or 62 feet.

Conversely, to **determine the maximum load on a run of known length**, divide the length into the constant. Example, a 36 foot run of #12 wire on a 6 volt systems can be loaded to, $534 \div 36$, or 14 watts; on #10 wire, 23 watts.

WIRING DISTANCE IN FEET (Maximum Voltage Drop 5%)													
Total watts on wire run	6 volt wire size				12 volt wire size					24 volt wire size			
	#12	#10	#8	#6	#12	#10	#8	#6	#4	#12	#10	#8	#6
6	89	141	225	357	356	566	900	1431	+	1425	+	+	+
8	66	106	168	268	267	424	675	1073	1707	1068	1698	+	+
9	59	94	150	238	237	377	600	954	1517	949	1509	+	+
10	53	84	135	214	213	339	540	859	1366	854	1358	+	+
12	44	70	112	178	178	283	450	715	1138	712	1132	1801	+
16	33	53	84	134	133	212	337	536	853	534	849	1350	+
18	29	47	75	119	118	188	300	477	758	474	754	1200	1909
24	22	35	56	89	89	141	225	357	569	356	566	900	1431
25	21	33	54	85	85	135	216	343	546	341	543	864	1374
27	19	31	50	79	79	125	200	318	505	316	503	800	1272
30	17	28	45	71	71	113	180	286	455	284	452	720	1145
36	14	23	37	59	59	94	150	238	379	237	377	600	954
42	12	20	32	51	50	80	128	204	325	203	323	514	818
45	11	18	30	47	47	75	120	190	303	189	301	480	763
48	11	17	28	44	44	70	112	178	284	178	283	450	715
50	10	16	27	42	42	67	108	171	273	170	271	432	687
75	7	11	18	28	28	45	72	114	182	113	181	288	458
100	5	8	13	21	21	33	54	85	136	85	135	216	343
150	—	5	9	14	14	22	36	57	91	56	90	144	229
200	—	—	6	10	10	16	27	42	68	42	67	108	171
250	—	—	5	8	8	13	21	34	54	34	54	86	137
300	—	—	—	7	7	11	18	28	45	28	45	72	114
400	—	—	—	5	5	8	13	21	34	21	33	54	85
500	—	—	—	—	—	6	10	17	27	17	27	43	68
Constant	534	849	1350	2148	2137	3397	5403	8590	13660	8548	13588	21613	34363

Longer Wire Runs

The wiring distances give the maximum length of a battery circuit, assuming that the entire load is concentrated at the end of the circuit. If loads are uniformly spaced along the circuit path (equal watts, equal distances), the lengths in the table may be increased, based on number of fixtures on a given circuit, by means of the chart and formula below.

Number of Fixtures	2	3	4	5	6	N
Multiply By Feet	1.33	1.5	1.6	1.67	1.71	$2n/(n+1)$

For example, a 36 foot long, 6 volt circuit has (3) 9 watt heads spaced 12 feet apart. According to the wire run table, # 8 wire must be used (at 50 feet for a 5% voltage drop.) but, by multiplying the 31 feet for #10 wire by 1.5, a 46 1/2 foot wire run is acceptable, so #10 wire may be used and still meet the 5% voltage drop limitation.

Note: According to the National Electrical Code, Article 720-Y, the smallest permissible wire size for systems under 50 volts is the #12 wire gauge.

National Electrical Code

ARTICLE 700—EMERGENCY SYSTEMS

A. General

700-1. Scope. The provisions of this article apply to the electrical safety of the installation, operation, and maintenance of emergency systems consisting of circuits and equipment intended to supply, distribute, and control electricity for illumination or power, or both, to required facilities when the normal electrical supply or system is interrupted.

Emergency systems are those systems legally required and classed as emergency by municipal, state, federal, or other codes, or by any governmental agency having jurisdiction. These systems are intended to automatically supply illumination or power, or both, to designated areas and equipment in the event of failure of the normal supply or in the event of accident to elements of a system intended to supply, distribute and control power and illumination essential for safety to human life.

(FPN No. 1): For further information regarding wiring and installation of emergency systems in health care facilities, see Article 517.

(FPN No. 2): For further information regarding performance and maintenance of emergency systems in health care facilities, see Standard for Health Care Facilities, NFPA 99-1999.

(FPN No. 3): Emergency systems are generally installed in places of assembly where artificial illumination is required for safe exiting and for panic control in buildings subject to occupancy by large numbers of persons, such as hotels, theaters, sports arenas, health care facilities, and similar institutions. Emergency systems may also provide power for such functions as ventilation where essential to maintain life, fire detection and alarm systems, elevators, fire pumps, public safety communications systems, industrial processes where current interruption would produce serious life safety or health hazards, and similar functions.

(FPN No. 4): For specification of locations where emergency lighting is considered essential to life safety, see *Life Safety Code*, NFPA 101-2000.

(FPN No. 5): For further information regarding performance of emergency and standby power systems, see Standard for Emergency and Standby Power Systems, NFPA 110-1999.

700-2. Application of Other Articles. Except as modified by this article, all applicable articles of this Code shall apply.

700-3. Equipment Approval. All equipment shall be approved for use on emergency systems.

700-4. Tests and Maintenance.

(a) **Conduct or Witness Test.** The authority having jurisdiction shall conduct or witness a test of the complete system upon installation and periodically afterward.

(b) **Tested Periodically.** Systems shall be tested periodically on a schedule acceptable to the authority having jurisdiction to ensure the systems are maintained in proper operating condition.

(c) **Battery Systems Maintenance.** Where battery systems or unit equipment are involved, including batteries used for starting, control, or ignition in auxiliary engines, the authority having jurisdiction shall require periodic maintenance.

(d) **Written Record.** A written record shall be kept of such tests and maintenance.

(e) **Testing Under Load.** Means for testing all emergency lighting and power systems during maximum anticipated load conditions shall be provided.

700-5. Capacity.

(a) **Capacity and Rating.** An emergency system shall have adequate capacity and rating for all loads to be operated simultaneously. The emergency system equipment shall be suitable for the maximum available fault current at its terminals.

(b) **Selective Load Pickup, Load Shedding, and Peak Load Shaving.** The alternate power source shall be permitted to supply emergency, legally required standby, and optional standby system loads where the source has adequate capacity or where automatic selective load pickup and load shedding is provided as needed to ensure adequate power to (1) the emergency circuits; (2) the legally required standby circuits; and (3) the optional standby circuits, in that order of priority. The alternate power source shall be permitted to be used for peak load shaving, provided the above conditions are met.

Peak load shaving operation shall be permitted for satisfying the test requirement of Section 700-4(b), provided all other conditions of Section 700-4 are met.

A portable or temporary alternate source shall be available whenever the emergency generator is out of service for major maintenance or repair.

700-6. Transfer Equipment.

(a) **General.** Transfer equipment, including automatic transfer switches, shall be automatic and identified for emergency use and approved by the authority having jurisdiction. Transfer equipment shall be designed and installed to prevent the inadvertent interconnection of normal and emergency sources of supply in any operation of the transfer equipment. Transfer equipment and electric power production systems installed to permit operation in parallel with the normal source shall meet the requirements of article 705.

(b) **Bypass Isolation Switches.** Means shall be permitted to bypass and isolate the transfer equipment. Where bypass isolation switches are used, inadvertent parallel operation shall be avoided.

(c) **Automatic transfer switches** shall be electrically operated and mechanically held.

(d) **Use.** Transfer equipment shall supply only emergency loads.

700-7. Signals. Audible and visual signal devices shall be provided, where practicable, for the following purposes described in 700.7(A) through (D).

(a) **Derangement.** To indicate derangement of the emergency source.

(b) **Carrying Load.** To indicate that the battery is carrying load.

(c) **Not Functioning.** To indicate that the battery charger is not functioning.

(d) **Ground Fault.** To indicate a ground fault in solidly grounded wye emergency systems of more than 150 volts to ground and circuit protective devices rated 1000 amperes or

more. The sensor for the ground-fault signal devices shall be located at, or ahead of, the main system disconnecting means for the emergency source, and the maximum setting of the signal devices shall be for a ground-fault current of 1200 amperes. Instructions on the course of action to be taken in event of indicated ground fault shall be located at or near the sensor location.

(FPN): For signals for generator sets, see *Standard for Emergency and Standby Power Systems*, NFPA 110-1999.

700-8. Signs.

(a) **Emergency Sources.** A sign shall be placed at the service entrance equipment indicating type and location of on-site emergency power sources.

Exception: A sign shall not be required for individual unit equipment as specified in Section 700-12(e).

(b) **Grounding.** Where the grounded circuit conductor connected to the emergency source is connected to a grounding electrode conductor at a location remote from the emergency source, there shall be a sign at the grounding location that shall identify all emergency and normal sources connected at that location.

B. Circuit Wiring

700-9. Wiring, Emergency System.

(a) **Identification.** All boxes and enclosures (including transfer switches, generators, and power panels) for emergency circuits shall be permanently marked so they will be readily identified as a component of an emergency circuit or system.

(b) **Wiring.** Unless otherwise permitted in (1) through (4), wiring from emergency source or emergency source distribution overcurrent protection to emergency loads shall be kept entirely independent of all other wiring and equipment. Wiring of two or more emergency circuits supplied from the same source shall be permitted in the same raceway, cable, box, or cabinet.

(1) Wiring from the normal power source located in transfer equipment enclosures.

(2) Wiring supplied from two sources in exit or emergency luminaire's (lighting fixtures)

(3) Wiring from two sources in a common junction box, attached to exit or emergency luminaire's (lighting fixtures).

(4) Wiring within a common junction box attached to unit equipment, containing only the branch circuit supplying the unit equipment and the emergency circuit supplied by the unit equipment.

(c) **Wiring Design and Location.** Emergency wiring circuits shall be designed and located to minimize the hazards that might cause failure due to flooding, fire, icing, vandalism, and other adverse conditions.

(d) **Fire Protection.** Emergency systems shall meet the following additional requirements in assembly occupancies for not less than 1000 persons or in buildings above 75 ft (23 m) in height with any of the following occupancy classes: assembly, educational, residential, detention and correctional, business, and mercantile.

(1) Feeder-circuit wiring shall meet one of the following conditions:

(1) Be installed in spaces or areas that are fully protected by an approved automatic fire suppression system.

(2) Be listed electrical circuit protective system with a minimum 1-hour fire rating.

(3) Be protected by a listed thermal barrier system for electrical system components.

(4) Be protected by a fire-rated assembly listed to achieve a minimum fire of 1 hour.

(5) Be embedded in not less than 2 in. (50 mm) of concrete.

(6) Be a cable listed to maintain circuit integrity for not less than 1 hour when installed in accordance with the listing requirements.

(2) **Feeder-Circuit Equipment.** Equipment for feeder circuits (transfer switches, transformers, panel boards) shall be either located in spaces fully protected by approved automatic fire suppression systems (sprinklers, carbon dioxide systems, etc.) or in spaces with a 1-hour fire resistance rating.

(FPN: For the definition of occupancy class, see Section 4.1 of *Life Safety Code*, NFPA 101-2000.

C. Sources of Power

700-12. General Requirements. Current supply shall be such that, in the event of failure of the normal supply to, or within, the building or group of buildings concerned, emergency lighting, emergency power, or both will be available within the time required for the application but not to exceed 10 seconds. The supply system for emergency purposes, in addition to the normal services to the building and meeting the general requirements of this section, shall be one or more of the types of systems described in 700.12(a) through (d) below. Unit equipment in accordance with Section 700.12(e) shall satisfy the applicable requirements of this article.

In selecting an emergency source of power, consideration shall be given to the occupancy and the type of service to be rendered, whether of minimum duration, as for evacuation of a theater, or longer duration, as for supplying emergency power and lighting due to an indefinite period of current failure from trouble either inside or outside the building.

Equipment shall be designed and located to minimize the hazards that might cause complete failure due to flooding, fires, icing, and vandalism.

Equipment for sources of power as described in Sections 700.12(a) through (d) where located within assembly occupancies for greater than 1000 persons or in buildings above 75 ft (23 m) in height with any of the following occupancy classes: assembly, educational, residential, detention and correctional, business, and mercantile, shall be installed either in spaces fully protected by approved automatic fire suppression systems (sprinklers, carbon dioxide systems, and so forth), or in spaces with a 1-hour fire rating.

FPN No. 1: For definition of occupancy class, see Section 4.1 of Life Safety Code, NFPA 101-2000.

FPN No. 2: Assignment of degree of reliability of the recognized emergency supply system depends on the careful evaluation of the variables at each particular installation.

(a) Storage Battery. Storage batteries used as source of power for emergency systems shall be of suitable rating and capacity to supply and maintain the total load for a period of 1 1/2 hours minimum, without the voltage applied to the load falling below 87 1/2 percent of normal.

Batteries, whether of the acid or alkali type, shall be designed and constructed to meet the requirements of emergency service and shall be compatible with the charger for that particular installation.

For a sealed battery, the container shall not be required to be transparent. However, for the lead acid battery that requires water additions, transparent or translucent jars shall be furnished. Automotive-type batteries shall not be used.

An automatic battery charging means shall be provided.

(b) Generator Set.

(1) Prime Mover-Driven. For a generator set driven by a prime mover acceptable to the authority having jurisdiction and sized in accordance with Section 700-5. Means shall be provided for automatically starting the prime mover on failure of the normal service and for automatic transfer and operation of all required electrical circuits. A time-delay feature permitting a 15-minute setting shall be provided to avoid retransfer in case of short-time reestablishment of the normal source.

(2) Internal Combustion as Prime Movers. Where internal combustion engines are used as the prime mover an on-site fuel supply shall be provided with an on-premise fuel supply sufficient for not less than 2 hours full-demand operation of the system. Where power is needed for the operation of the fuel transfer pumps to deliver fuel to a generator set dry tank, this pump shall be connected to the emergency power system.

(3) Dual Supplies. Prime movers shall not be solely dependent upon a public utility gas system for their fuel supply or municipal water supply for their cooling systems. Means shall be provided for automatically transferring from one fuel supply to another where dual fuel supplies are used.

Exception: Where acceptable to the authority having jurisdiction, the use of other than on-site fuels shall be permitted where there is a low probability of a simultaneous failure of both the off-site fuel delivery system and power from the outside electrical utility company.

(4) Where a storage battery is used for control or signal power, or as the means of starting the prime mover, it shall be suitable for the purpose and shall be equipped with an automatic charging means independent of the generator set. Where the battery charger is required for the operation of the generator set, it shall be connected to the emergency system. Where power is required for the operation of dampers used to ventilate the generator set, the dampers shall be connected to the emergency system.

(5) Auxiliary Power Supply. Generator sets that require more than 10 seconds to develop power shall be permitted is an auxiliary power supply energizes the emergency system until the generator can pick up the load.

(6) Outdoor Generator Sets. Where an outdoor housed generator set is equipped with a readily accessible disconnecting means located within sight of the building or structure supplied, an additional disconnecting means shall not be required where ungrounded conductors serve or pass through the building or structure.

(c) Uninterruptible Power Supplies. Uninterruptible power supplies used to provide power for emergency systems shall comply with the applicable provisions of Sections 700-12(a) and (b).

(d) Separate Service. Where acceptable to the authority having jurisdiction as suitable for use as an emergency source of power, an additional service shall be permitted. This service shall be in accordance with the applicable provisions of Article 230 and following additional requirements.

(1) Separate service drop or service lateral

(2) Service conductors sufficiently remote electrically and physically from any other service conductors to minimize the possibility of simultaneous interruption of supply

(e) Fuel Cell System. Fuel Cell Systems used as a source of power for emergency systems shall be of suitable rating and capacity to supply and maintain the total load for not less than 2 hours of full-demand operation.

Installation of a fuel cell system shall meet the requirements of Parts II through VIII of Article 692.

Where a single fuel cell system serves as the normal supply for the building or group of buildings concerned, it shall not serve as the sole source of power for the emergency standby system.

(f) Unit Equipment. Individual unit equipment for emergency illumination shall consist of (1) a rechargeable battery; (2) a battery charging means (3) provisions for one or more lamps mounted on the equipment, or shall be permitted to have terminals for remote lamps, or both; and (4) a relaying device arranged to energize the lamps automatically upon failure of the supply to the unit equipment.

The batteries shall be of suitable rating and capacity to supply and maintain at not less than 87 1/2 percent of the nominal battery voltage for the total lamp load associated with the unit for a period of at least 1 1/2 hours, or the unit equipment shall supply and maintain not less than 60 percent of the initial emergency illumination for a period of at least 1 1/2 hours. Storage batteries, whether of the acid or alkali type, shall be designed and constructed to meet the requirements of emergency service.

Unit equipment shall be permanently fixed in place (i.e., not portable) and shall have all wiring to each unit installed in accordance with the requirements of any of the wiring

methods in Chapter 3. Flexible cord and plug connection shall be permitted, provided that the cord does not exceed 3 ft (900 mm) in length. The branch circuit feeding the unit equipment shall be the same branch circuit as that serving the normal lighting in the area and connected ahead of any local switches. The branch circuit that feeds unit equipment shall be clearly identified at the distribution panel. Emergency luminaire(s) (illumination fixtures) that obtain power from a unit equipment and are not part of the unit equipment shall be wired to the unit equipment as required by Section 700-9 and by one of the wiring methods of Chapter 3.

Exception: In a separate and uninterrupted area supplied by a minimum of three normal lighting circuits, a separate branch circuit for unit equipment shall be permitted if it originates from the same panelboard as that of the normal lighting circuits and is provided with a lock-on feature.

D. Emergency System Circuits for Lighting and Power

700-15. Loads on Emergency Branch Circuits. No appliances and no lamps, other than those specified as required for emergency use, shall be supplied by emergency lighting circuits.

700-16. Emergency Illumination. Emergency illumination shall include all required means of egress lighting, illuminated exit signs, and all other lights specified as necessary to provide required illumination.

Emergency lighting systems shall be designed and installed so that the failure of any individual lighting element, such as the burning out of a light bulb, cannot leave in total darkness any space that requires emergency illumination.

Where high-intensity discharge lighting such as high- and low-pressure sodium mercury vapor, and metal halide is used as the sole source of normal illumination, the emergency lighting system shall be required to operate until normal illumination has been restored.

Exception: Where alternative means that ensure the emergency lighting illumination level is maintained shall be permitted.

700-17. Circuits for Emergency Lighting. Branch circuits that supply emergency lighting shall be installed to provide service from a source complying with Section 700-12 when the normal supply for lighting is interrupted. Such installations shall provide either one of the following: (1) an emergency lighting supply, independent of the general lighting supply, with provisions for automatically transferring the emergency lights upon the event of failure of the general lighting system supply, or (2) two or more separate and complete systems with independent power supply, each system providing sufficient current for emergency lighting purposes.

Unless both systems are used for regular lighting purposes and are both kept lighted, means shall be provided for automatically energizing either system upon failure of the other. Either or both systems shall be permitted to be a part of the general lighting system of the protected occupancy if circuits supplying lights for emergency illumination are installed in accordance with other sections of this article.

700-18. Circuits for Emergency Power. For branch circuits that supply equipment classed as emergency, there shall be an emergency supply source to which the load will be transferred automatically upon the failure of the normal supply.

E. Control—Emergency Lighting Circuits

700-20. Switch Requirements. The switch or switches installed in emergency lighting circuits shall be arranged so that only authorized persons will have control of emergency lighting.

Exception No. 1: Where two or more single-throw switches are connected in parallel to control a single circuit, at least one of these switches shall be accessible only to authorized persons.

Exception No. 2: Additional switches that act only to put emergency lights into operation but not disconnect them shall be permissible.

Switches connected in series or 3- and 4-way switches shall not be used.

700-21. Switch Location. All manual switches for controlling emergency circuits shall be in locations convenient to authorized persons responsible for their actuation. In facilities covered by Articles 518 and 520, a switch for controlling emergency lighting systems shall be located in the lobby or at a place conveniently accessible thereto.

In no case shall a control switch for emergency lighting be placed in a motion-picture projection booth or on a stage or platform.

Exception: Where multiple switches are provided, one such switch shall be permitted in such locations where arranged so that it can energize the circuit only, but cannot de-energize the circuit.

700-22. Exterior Lights. Those lights on the exterior of a building that are not required for illumination when there is sufficient daylight shall be permitted to be controlled by an automatic light-actuated device.

F. Overcurrent Protection

700-25. Accessibility. The branch-circuit overcurrent devices in emergency circuits shall be accessible to authorized persons only.

(FPN): Fuses and circuit breakers for emergency circuit overcurrent protection where coordinated to ensure selective clearing of fault currents, increase overall reliability of the system.

700-26. Ground-Fault Protection of Equipment. The alternate source for emergency systems shall not be required to have ground-fault protection of equipment with automatic disconnecting means. ground-fault indication of the emergency source shall be provided per Section 700-7(d).

700-27. Coordination. Emergency system(s) overcurrent devices shall be selectively coordinated with all supply side overcurrent protective devices.

Life Safety Code

7.8 Illumination of Means of Egress.

7.8.1 General.

7.8.1.1* Illumination of means of egress shall be provided in accordance with Section 7.8 for every building and structure where required in Chapter 11 through Chapter 42. For the purposes of this requirement, exit access shall include only designated stairs, aisles, corridors, ramps, escalators, and passageways leading to an exit. For the purposes of this requirement, exit discharge shall include only designated stairs, aisles, corridors, ramps, escalators, walkways, and exit passageways leading to a public way.

7.8.1.2 Illumination of means of egress shall be continuous during the time that the conditions of occupancy require that the means of egress be available for use, unless otherwise provided in 7.8.1.2.2.

7.8.1.2.1 Artificial lighting shall be employed at such locations and for such periods of time as are necessary to maintain the illumination to the minimum criteria values herein specified.

7.8.1.3* The floors and other walking surfaces within an exit and within the portions of the exit access and exit discharge designated by 7.8.1.1 shall be illuminated as follows:

- (1) During conditions of stair use, the minimum illumination for new stairs shall be at least 10 ft-candle (108 lux), measured at the walking surfaces.
- (2) The minimum illumination for floors and walking surfaces, other than new stairs during conditions of stair use, shall be to values of at least 1 ft-candle (10.8 lux), measured at the floor.
- (3) In assembly occupancies, the illumination of the floors of exit access shall be at least 0.2 ft-candle (2.2 lux) during periods of performances or projections involving directed light.
- (4) *The minimum illumination requirements shall not apply where operations or processes require low lighting levels.

7.8.1.4* Required illumination shall be arranged so that the failure of any single lighting unit does not result in an illumination level of less than 0.2 ft-candle (2.2 lux) in any designated area.

7.8.1.5 The equipment or units installed to meet the requirements of Section 7.10 also shall be permitted to serve the function of illumination of means of egress, provided that all requirements of section 7.8 for such illumination are met.

7.8.2 Sources of Illumination.

7.8.2.1* Illumination of means of egress shall be from a source of considered reliable by the authority having jurisdiction.

7.8.2.2 Battery-operated electric lights and other types of portable lamps or lanterns shall not be used for primary illumination of means of egress. Battery-operated electric lights shall be permitted to be used as an emergency source to the extent permitted under Section 7.9

7.9 Emergency Lighting.

7.9.1 General.

7.9.1.1* Emergency lighting facilities for means of egress shall be provided in accordance with Section 7.9 for the following:

- (1) Buildings or structures where required in Chapter 11 through Chapter 42
- (2) Underground and limited access structures as addressed in Section 11.7
- (3) High-rise buildings as required by other sections of this *Code*
- (4) Doors equipped with delayed-egress locks

5) Stair shaft and vestibule of smokeproof enclosures, for which the following also apply:

- (a) The stair shaft and vestibule shall be permitted to include a standby generator that is installed for the smokeproof enclosure mechanical ventilation equipment.
- (b) The standby generator shall be permitted to be used for the stair shaft and vestibule emergency lighting power supply.
- (6) New access-controlled egress doors in accordance with 7.2.1.6.2.

7.9.1.2 For the purposes of 7.9.1.1, exit access shall include only designated stairs, aisles, corridors, ramps, escalators, and passageways leading to an exit. For the purposes of 7.9.1.1, exit discharge shall include only designated stairs, ramps, aisles, walkways, and escalators leading to a public way.

7.9.1.3 Where maintenance of illumination depends on changing from one energy source to another, a delay of not more than 10 seconds shall be permitted.

7.9.2 Performance of System.

7.9.2.1* Emergency illumination shall be provided for not less than 1-1/2 hours in the event of failure of normal lighting. Emergency lighting facilities shall be arranged to provide initial illumination that is not less than an average of 1 ft-candle (10.8 lux) and, at any point, not less than 0.1 ft-candle (1.1 lux) measured along the path of egress at floor level. Illumination levels shall be permitted to decline to not less than an average of 0.6 ft-candle (6.5 lux) and, at any point, not less than 0.06 ft-candle (0.65 lux) at the end of the 1-1/2 hours. A maximum-to-minimum illumination uniformity ratio of 40 to 1 shall not be exceeded.

7.9.2.2 New emergency power systems for emergency lighting shall be at least Type 10, Class 1.5, Level 1, in accordance with NFPA 110, *Standard for Emergency and Standby Power Systems*.

7.9.2.3* The emergency lighting system shall be arranged to provide the required illumination automatically in the event of any of the following:

- (1) Failure of public utility or other outside electrical power supply
- (2) Opening of a circuit breaker or fuse
- (3) Manual act(s), including accidental opening of a switch controlling normal lighting facilities

7.9.2.4 Emergency generators providing power to emergency lighting systems shall be installed, tested, and maintained in accordance with NFPA 110, *Standard for Emergency and Standby Power Systems*. Stored electrical energy systems where required in this *Code*, shall be installed and tested in accordance with NFPA 111, *Standard on Stored Electrical Energy Emergency and Standby Power Systems*.

7.9.2.5 Unit equipment and battery systems for emergency luminaires shall be listed to UL 924, *Standard for Emergency Lighting and Power Equipment*.

7.9.2.6* Existing battery-operated emergency lights shall use only reliable types of rechargeable batteries provided with suitable facilities for maintaining them in properly charged condition. Batteries used in such lights or units shall be approved for their intended use and shall comply with NFPA 70, *National Electrical Code*.

7.9.2.7 The emergency lighting system shall be either continuously in operation or shall be capable of repeated automatic operation without manual intervention.

7.9.3 Periodic Testing of Emergency Lighting Equipment.

7.9.3.1 Required emergency lighting systems shall be tested in accordance with one of the three options offered by 7.9.3.1.1, 7.9.3.1.2, or 7.9.3.1.3.

7.9.3.1.1 Testing of required emergency lighting systems shall be permitted to be conducted as follows:

- (1) Functional testing shall be conducted at 30-day intervals for not less than 30 seconds.
- (2) Functional testing shall be conducted annually for not less than 1-1/2 hours if the emergency lighting system is battery powered.
- (3) The emergency lighting equipment shall be fully operational for the duration of the tests required by 7.9.3.1.1 (1) and 7.9.3.1.1 (2).
- (4) Written records of visual inspections and tests shall be kept by the owner for inspection by the authority having jurisdiction.

7.9.3.1.2 Testing of required emergency lighting systems shall be permitted to be conducted as follows:

- (1) Self-testing/self-diagnostic battery-operated emergency lighting equipment shall be provided.
- (2) Self-testing/self-diagnostic, battery-operated emergency lighting equipment shall automatically perform not less than once every 30 days a test for not less than 30 seconds and a diagnostic routine.
- (3) Self-testing/self-diagnostic battery-operated emergency lighting equipment shall indicate failures by a status indicator.
- (4) A visual inspection shall be performed at intervals not exceeding 30 days.
- (5) Functional testing shall be conducted annually for not less than 1-1/2 hours.
- (6) Self-testing/self-diagnostic battery-operated emergency lighting equipment shall be fully operational for the duration of the 1-1/2 hour test.
- (7) Written records of visual inspections and tests shall be kept by the owner for inspection by the authority having jurisdiction.

7.9.3.1.3 Testing of required emergency lighting systems shall be permitted to be conducted as follows:

- (1) Computer-based, self-testing/self-diagnostic battery-operated emergency lighting equipment shall be provided.
- (2) The emergency lighting equipment shall automatically perform not less than once every 30 days a test for not less than 30 seconds and a diagnostic routine.
- (3) The emergency lighting equipment shall automatically perform annually a test for not less than 1-1/2 hours.
- (4) The emergency lighting equipment shall be fully operational for the duration of the tests required by 7.9.3.1.3(2) and 7.9.3.1.3(3).
- (5) The computer-based system shall be capable of providing a report of the history of tests and failures at all times.

7.10 Marking of Means of Egress.

7.10.1 General.

7.10.1.1 Where Required. Means of egress shall be marked in accordance with section 7.10 where required in Chapter 11 through Chapter 42.

7.10.1.2* **Exits.** Exits, other than main exterior exit doors that obviously and clearly are identifiable as exits, shall be marked by an approved sign that is readily visible from any direction of exit access.

7.10.1.3 **Exit Door Tactile Signage.** Tactile signage shall be provided to meet the following criteria, unless otherwise provided in 7.10.1.4:

- (1) Tactile signage shall be located at each exit door requiring an exit sign.
- (2) Tactile signage shall read as follows: EXIT.
- (3) Tactile signage shall comply with ICC/ANSI A117.1, *American National Standard for Accessible and Usable Buildings and Facilities*.

7.10.1.4 **Existing Exemption.** The requirements of 7.10.1.3 shall not apply to existing buildings, provided that the occupancy classification does not change.

7.10.1.5 Exit Access.

7.10.1.5.1 Access to exits shall be marked by approved, readily visible signs in all cases where the exit or way to reach the exit is not readily apparent to the occupants.

7.10.1.5.2* New sign placement shall be such that no point in an exit access corridor is in excess of the rated viewing distance or 100 ft (30 m), which ever is less, from the nearest sign.

7.10.1.6* **Floor Proximity Exit Signs.** Where floor proximity exit signs are required by Chapter 11 through Chapter 42, such signs shall be located near the floor level in addition to those signs required for doors or corridors. These signs shall be illuminated in accordance with 7.10.5. Externally illuminated signs shall be sized in accordance with 7.10.6.1. The bottom of the sign shall be not less than 6 in. (150 mm), but not more than 18 in. (455 mm), above the floor. For exit doors, the sign shall be mounted on the door or adjacent to the door, with the nearest edge of the sign within 4 in. (100 mm) of the door frame.

7.10.1.7* **Floor Proximity Egress Path Marking.** Where floor proximity egress path marking is required in Chapter 11 through Chapter 42, a listed and approved floor proximity egress path marking system that is internally illuminated shall be installed within 18 in. (455 mm) of the floor. The system shall provide a visible delineation of the path of travel along the designated exit access and shall be essentially continuous, except as interrupted by doorways, hallways, corridors, or other such architectural features. The system shall operate continuously or at any time the building fire alarm system is activated. The activation, duration, and continuity of operation of the system shall be in accordance with 7.9.2. The system shall be maintained in accordance with the product manufacturing listing.

7.10.1.8* **Visibility.** Every sign required in Section 7.10 shall be located and of such size, distinctive color, and design that it is readily visible and shall provide contrast with decorations, interior finish, or other signs. No decorations, furnishings, or equipment that impairs visibility of a sign shall be permitted. No brightly illuminated sign (for other than exit purposes), display, or object in or near the line of vision of the required exit sign that could detract attention from the exit sign shall be permitted.

7.10.1.9 **Mounting Location.** The bottom of new egress markings shall be located at a vertical distance of not more than 6 ft 8 in. (2030 mm) above the top edge of the egress opening intended for designation by that marking. Egress markings shall be located at a horizontal distance of not more than the required width of the egress opening, as measured from the edge of the egress opening intended for designation by that marking to the nearest edge of the marking.

7.10.2* **Directional Signs.** A sign complying with 7.10.3 with a directional indicator showing the direction of travel shall be placed in every location where the direction of travel to reach the nearest exit is not apparent.

7.10.3* Sign Legend.

7.10.3.1 Signs required by 7.10.1 and 7.10.2 shall read as follows in plainly legible letters, or other appropriate working shall be used:

EXIT

7.10.3.2* Where approved by the authority having jurisdiction, pictograms shall be permitted.

7.10.4* **Power Source.** Where emergency lighting facilities are required by the applicable provisions of Chapter 11 through Chapter 42 for individual occupancies, the signs, other than approved self-luminous signs and listed photoluminescent signs in accordance with 7.10.7.2, shall be illuminated by the emergency lighting facilities. The levels of illumination of the signs shall be in accordance with 7.10.6.3 or 7.10.7 for the required emergency lighting duration as specified in 7.9.2.1. However, the level of illumination shall be permitted to decline to 60 percent at the end of the emergency lighting duration.

Life Safety Code (cont'd)

7.10.5 Illumination of Signs.

7.10.5.1* General. Every sign required by 7.10.1.2, 7.10.1.5, or 7.10.8.1, other than where operations or processes require low lighting levels, shall be suitably illuminated by a reliable light source. Externally and internally illuminated signs shall be legible in both the normal and emergency lighting mode.

7.10.5.2* Continuous Illumination.

7.10.5.2.1 Every sign required to be illuminated by 7.10.6.3, 7.10.7, and 7.10.8.1 shall be continuously illuminated as required under the provisions of Section 7.8, unless otherwise provided in 7.10.5.2.2.

7.10.6 Externally Illuminated Signs.

7.10.6.1* Size of Signs.

7.10.6.1.1 Externally illuminated signs required by 7.10.1 and 7.10.2, other than approved existing signs, unless otherwise provided in 7.10.6.1.2, shall read EXIT or shall use other appropriate wording in plainly legible letters sized as follows:

- (1) For new signs, the letters shall be not less than 6 in. (150 mm) high, with the principal strokes of letters not less than 3/4 in. (19 mm) wide.
- (2) For existing signs, the required wording shall be permitted to be in plainly legible letters not less than 4 in. (100 mm) high.
- (3) The word EXIT shall be in letters of a width not less than 2 in. (51 mm), except the letter I, and the minimum spacing between letters shall be not less than 3/8 in. (9.5 mm).
- (4) Signs legend elements larger than the minimum established in 7.10.6.1.1(1) through 7.10.6.1.1(3) shall use letter widths, strokes, and spacing in proportion to their height.

7.10.6.1.2 The requirements of 7.10.6.1.1 shall not apply to marking required by 7.10.1.3 and 7.10.1.6.

7.10.6.2* Size and Location of Directional Indicator.

7.10.6.2.1 Directional indicators, unless otherwise provided in 7.10.6.2.2, shall comply with the following:

- (1) The directional indicator shall be located outside of the EXIT legend, not less than 3/8 in. (9.5 mm) from any letter.
- (2) The directional indicator shall be of a chevron type, as shown in Figure 7.10.6.2.1.
- (3) The directional indicator shall be identifiable as a directional indicator at a distance of 40 ft (12 m).
- (4) A directional indicator larger than the minimum established for compliance with 7.10.6.2.1(3) shall be proportionately increased in height, width, and stroke.
- (5) The directional indicator shall be located at the end of the sign for the direction indicated.



Figure 7.10.6.2.1 Chevron-Type Indicator.

7.10.6.2.2 The requirements of 7.10.6.2.1 shall not apply to approved existing signs.

7.10.6.3* Level of Illumination. Externally illuminated signs shall be illuminated by not less than 5 ft-candles (54 lux) at the illuminated surface and shall have a contrast ratio of not less than 0.5.

7.10.7 Internally Illuminated Signs.

7.10.7.1 Listing. Internally illuminated signs shall be listed in accordance with UL 924, *Standard for Emergency Lighting and Power Equipment*, unless they meet one of the following criteria:

- (1) They are approved existing signs.
- (2) They are existing signs having the required wording in legible letters not less than 4 in. (100 mm) high.
- (3) They are signs that are in accordance with 7.10.1.3 and 7.10.1.6.

7.10.7.2* Photoluminescent Signs. The face of a photoluminescent sign shall be continually illuminated while the building is occupied. The illumination levels on the face of the photoluminescent sign shall be in accordance with its listing. The charging illumination shall be a reliable light source as determined by the authority having jurisdiction. The charging light source shall be of a type specified in the product markings.

7.10.8 Special Signs.

7.10.8.1 Sign Illumination.

7.10.8.1.1 Where required by other provisions of this *Code*, special signs shall be illuminated in accordance with 7.10.5, 7.10.6.3, and 7.10.7.

7.10.8.1.2 Where emergency lighting facilities are required by the applicable provisions of Chapter 12 through Chapter 42, the required illumination of special signs shall additionally be provided under emergency lighting conditions.

7.10.8.2 Characters. Special signs, where required by other provisions of this *Code*, shall comply with the visual character requirements of ICC/ANSI A117.1, *American National Standard for Accessible and Usable Buildings and Facilities*.

7.10.8.3* No Exit.

7.10.8.3.1 Any door, passage, or stairway that is neither an exit nor a way of exit access and that is located or arranged so that it is likely to be mistaken for an exit shall be identified by a sign that reads as follows.

NO
EXIT

7.10.8.3.2 The NO EXIT sign shall have the word NO in letters 2 in. (51 mm) high, with a stroke width of 3/8 in. (9.5 mm), and the word EXIT in letters 1 in. (25 mm) high, with the word EXIT below the word NO, unless such sign is an approved existing sign.

7.10.9 Testing and Maintenance.

7.10.9.1 Inspection. Exit signs shall be visually inspected for operation of the illumination sources at intervals not to exceed 30 days or shall be periodically monitored in accordance with 7.9.3.1.3.

7.10.9.2 Testing. Exit signs connected to or provided with a battery-operated emergency illumination source, where required in 7.10.4, shall be tested and maintained in accordance with 7.9.3.

NFPA 101® Life Safety Code® 2006 Edition

©2005, NFPA, All Rights Reserved

Life Safety Code® and NFPA 101® are registered trademarks of the National Fire Protection Association, Inc.



Limited Warranty

- 1.0 Lightalarms 6, 12 and 24 volt Emergency Lighting Unit Equipment (excluding lamps and fuses) are fully warranted to be free of defects in material and workmanship under normal use for a period of three years from date of installation (see Paragraph 2.0).
- 1.1 Lightalarms 6, 12 and 24 volt Unit Equipment Batteries are warranted as follows (Warrant below includes the 3-year full warranty on entire unit as called out in Paragraph 1.0).
- 1.2 Lightalarms 4 volt Emergency Lighting Unit Equipment (excluding lamps, and fuses) is fully warranted to be free of defects in material and workmanship under normal use for a period of one year from date of installation (see Paragraph 2.0).

BATTERY TYPE	LIFE EXPECTANCY	SHELF LIFE*	FULL WARRANTY	PRO RATA WARRANTY
Sealed Lead-Calcium	8 years	6 months	3 years	3 years
Sealed Lead-Calcium (Immobilized Electrolyte)	12 years	6 months	5 years	5 years
Sealed Long Life Lead	12 years	6 months	5 years	5 years
Sealed Nickel-Cadmium	15 years	1 year	5 years	7 years
Refillable Lead-Calcium	15 years	6 months	3 years	8 years
Refillable Nickel-Cadmium	15 years	2 years	5 years	7 years

***Maximum Storage life. Must Be Recharged If Not Placed in Service Or Battery Warranty Void**

- 2.0 The full warranty period begins on the date of installation or 90 days from date of shipment, whichever date is earlier.
- 2.1 Should a defect appear in the equipment or batteries listed in Paragraphs 1.0, 1.1 or 1.2 above within the specified full warranty period, Lightalarms will repair or replace equipment without charge (see Paragraph 3.3). Such repair or replacement shall be the purchaser's exclusive remedy.
- 2.2 The Pro-rata Warranty Period for batteries begins on the date the full warranty period ends.
- 2.3 A battery determined to be defective during the Pro Rata Warranty Period shall be repaired or replaced at a cost equal to the net price in effect at the time, reduced by the percentage obtained in multiplying 10% by the number of full years remaining in the total warranty period. Such repair or replacement at this adjusted price shall be the purchaser's exclusive remedy.
- 3.0 All warranties are subject to proper installation and maintenance in accordance with the instructions supplied.
- 3.1 Any material deemed defective must be returned, freight prepaid, to the factory for evaluation (see Paragraph 5.0-5.3). Any changes in circuitry or components by other than authorized Lightalarms personnel or its service companies will void the warranty.
- 3.2 All warranties are limited to the repair and/or replacement or parts or equipment, which, upon examination at our plant, are determined to be defective and in our judgement are subject to repair or replacement under warranty. Replacement of lamps and fuses is not included in the warranty.
- 3.3 If new replacement parts are shipped before defective goods are received for evaluation, the replacement parts will be invoiced at the net price in effect at that time. These charges will be credited if, upon receipt and evaluation of goods, a defect is determined. Only replacement parts will be shipped under these circumstances, if field replacement is possible. **Lightalarms FACTORY ONLY RESERVES THE RIGHT TO SHIP NEW UNIT EQUIPMENT FOR REPLACEMENT PURPOSES.** Units returned after installation cannot be restored to 100% saleable condition.
- 4.0 In no event shall Lightalarms be liable for backcharges of any kind, including, without limitation, labor charges for field repair or late penalties.
- 4.1 This warranty does not cover damages caused by improper maintenance of installation or damage due to installation in areas with other than normal temperatures and environmental conditions per application specifications. Lightalarms assumes no responsibility for any damage to people, property, apparatus or otherwise resulting from improper installation or maintenance of its Emergency Lighting Unit Equipment.
- 4.2 This warranty does not cover damages caused by abuse, fire or Act of God.
- 4.3 In no event shall Lightalarms be liable for incidental or consequential damages.
- 4.4 The foregoing warranty is in lieu of all other warranties, expressed or implied, or merchantability, fitness for a particular purpose or any other thing. Except as stated in this warranty, Lightalarms shall not be liable for any defects in, or breach of any contract relating to, the quality of performance of Lightalarms Equipment under any theory of law including, without limitation, contract, negligence, strict liability or misrepresentation.
- 4.5 Lightalarms warranty coverage shall not apply to any equipment of another manufacturer used in conjunction with Lightalarms Equipment.
- 4.6 Some states do not allow limitation on how long an implied warranty lasts, so the above limitation may not apply to you. Some states do not allow the exclusion or limitation of incidental or consequential damages, so the above limitation or exclusion may not apply to you. This written warranty gives you specific legal rights and you may also have other rights which vary from state to state.
- 5.0 No returned defective materials will be accepted without a Returned Goods Authorization issued in writing by an authorized Lightalarms employee.
- 5.1 Purchaser is responsible for secure packing of returned materials to provide best possible assurance against damage in shipment.
- 5.2 Defective batteries of any kind must not be returned to Lightalarms's factory without strict adherence to special instructions for handling and shipping. **WARNING** Never ship a refillable wet battery in any type of emergency lighting equipment. Failure to adhere to this policy will void warranty.
- 5.3 Defective goods returned to the factory must be shipped prepaid. **COLLECT RETURNED SHIPMENT WILL BE REFUSED.** Freight charges to return repaired equipment or ship replacement equipment to the purchaser to be paid by Lightalarms. Factory will return repaired goods via same shipping method as received.

FAILURE TO COMPLY WITH ANY OF THE STIPULATIONS SET FORTH WILL VOID THE WARRANTY.

ANY EXCEPTIONS TO THE FOREGOING WARRANTY MUST BE REQUESTED AND ACCEPTED IN WRITING PRIOR TO SHIPMENT.

Lightalarms EQUIPMENT NOT LISTED IN PARAGRAPHS 1.0, 1.1 OR 1.2 IS WARRANTED AS DESCRIBED ON ITS INDIVIDUAL DATA SHEET WITH THE STIPULATIONS AS STATED IN PARAGRAPHS 2.0-5.3.