



WP Series

6 or 12 Volt Weatherproof Emergency Unit Maintenance-Free Lead-Calcium, Wet Refillable Lead Acid or Wet Refillable Nickel-Cadmium Battery

The WP Series battery unit is designed with a special enclosure for applications where a weatherproof unit is required.

FEATURES

Reliability

The WP Series has a three-year full warranty (excluding lamps and fuses).

Unit Data

The housing is constructed of heavy-duty steel with front access to the battery and all components. The housing has a galvanized undercoating and baked gray enamel finish. Knockout and controls are concealed at bottom of housing. Welded mounting brackets are provided on top of case.

Lamp

Standard WP Series units are furnished with two, Par 36 size, high impact mar-resistant thermoplastic heads suitable for external use, furnished with high intensity incandescent lamps. The heads are fully adjustable horizontally and vertically. Optional lamps are available.

Pulse Type Charger

- Automatic, temperature compensated, pulse type charger.
- High capacity, automatic, dust-tight instantaneous transfer relay.
- Low voltage disconnect prevents over discharge of battery. Automatic brownout protection is provided.
- Labor saving AC line latch prevents battery discharge during installation to a non-energized circuit.
- Fused output circuit.

Controls

- Red charger monitor LED indicates state of charge of the battery.
- Amber AC-ON LED indicates AC power is on.
- Momentary test switch allows for quick operational check of entire system.

Power Requirements

120/277Vac 60Hz, 0.3/0.15 Amp

OPTIONS

(Add Suffix to Model No.)		Suffix
Voltmeter		-V
Ammeter		-A
Thermal Jacket (120V Heater)		-H1
Thermal Jacket (277V Heater)		-H2
Time Delay (12 minutes)		-TD
Lamp Disconnect Switch		-DS
3-Wire Cord & Plug Kit		WP-3CP *
3-Wire Cord & Plug (277V) Kit		WP-3CP-277 *

*Standard cord is 3 ft. custom lengths available.

ACCESSORIES

(Order as a separate item)

Wire Guard.....WG4

DIMENSIONS

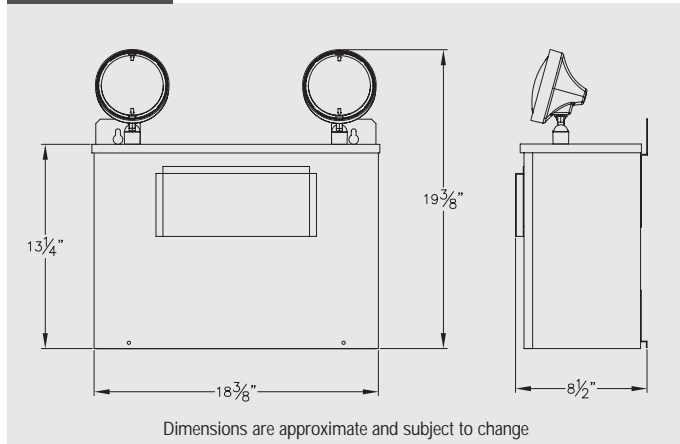

UNIT SELECTION CHART

Volts	Model No. (unit/Lamp Suffix)	Battery Type	*Watts to 87-1/2% of Rated Battery Voltage			
			1-1/2 Hrs.	2 Hrs.	3 Hrs.	4 Hrs.
6	2SL3-WP/4510	Lead-Acid	100	80	50	40
	2SL9-WP/4510		200	150	125	100
	2SL105-WP/4510		200	200	175	125
12	2B12L-3-WP/4446		170	150	100	75
6	2SN2-WP/4510	Nickel-Cadmium	50	45	25	18
	2SN3-WP/4510		70	60	35	25
	2SN4-WP/4510		100	80	50	35
	2SN6-WP/4510		130	105	70	50
	2SN7-WP/4510		160	130	80	60
12	2S12E4-WP/4446	Sealed Lead	200	150	100	75
	2S12E5-WP/4446	Lead	300	225	110	110
	2S12E6-WP/4446	Calcium	400	300	150	150

*National Electrical Code Specification

Note: Above capacity ratings are subject to an ambient of 50 to 85 degrees. Extremes of temperatures beyond this range will have a detrimental effect on the specified ratings. For extreme cold, use of a thermal jacket is recommended.

ORDERING FORMAT

2	SL	9	-WP	/4510	-V
No. of Heads	Series	Capacity Indicator	Weatherproof Enclosure Series	Lamp Suffix 6V 25W Incandescent	Option (Voltmeter)