

LCA-2MR Series



6 Volt Thermoplastic Battery Unit
Damp Location Listing is standard on all models
Sealed Maintenance-Free Lead Calcium Battery
UL Listed

The LCA-2MR Series, is the perfect battery unit for use where style and design are required in an economical package.

FEATURES

Reliability

The LCA-2MR Series has a three-year full warranty (excluding lamps and fuses).

Unit Data

The unit is completely self-contained and the housing is constructed of high impact, UL recognized, 94, 5VA thermoplastic. The compact design will allow for space restrictions often encountered. The snap together housing facilitates mounting in any orientation.

Lamp

Furnished with two 6 volt, MR16 glare free halogen lamp heads

Charger

- Automatic, temperature compensated, charger.
- High capacity, automatic, dust-tight instantaneous transfer relay.
- Low voltage disconnect prevents over discharge of battery. Automatic brownout protection is provided.
- Labor saving AC line latch prevents battery discharge during installation to a non-energized circuit.

ACCESSORIES

(Order as a separate item)

Replacement MR16 Lamp.....	580.0072
Wire Guard.....	WG13

DIMENSIONS

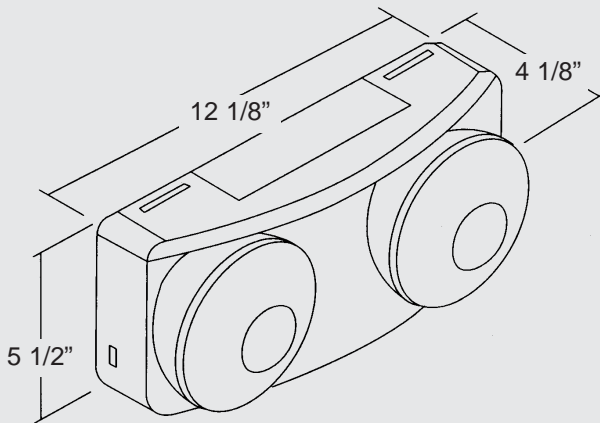

Dimensions are approximate and subject to change

ORDERING FORMAT

LCA

Series

-2MR

Light Heads

-2MR=

6V 5W MR16 Halogen