

IC-2 Series

6 Volt Ultra-Slim Emergency Unit Sealed Maintenance-Free Lead Calcium Battery UL Listed



The IC-2 Series, is an aesthetically attractive, economical unit ideal for commercial or institutional facilities. This unit offers reliable performance in a low profile, contemporary design.

FEATURES

Reliability

The IC-2 Series has a three-year full warranty (excluding lamps and fuses).

Unit Data

The compact, ultra-slim housing and prismatic lenses are constructed of an injection-molded, tough thermoplastic body that will not scratch or corrode. It has a lightly textured "mist white" finish that blends well with any décor. All units come with a pre-wired AC to save time and installation costs. Simply wire the mounting plate to the building AC and secure. Then, using the AC quick connect plug, snap the housing onto the mounting plate and the unit is ready to be powered. Attractive and versatile, the IC-2 Series battery units can be mounted in any orientation on walls and ceilings. Available as a remote fixture; see Remote Fixtures section of this catalogue.

Lamp

Standard with two 6-watt, high intensity, all glass, wedge base incandescent lamps. Alternate lamp sockets shall be provided to adjust photometric pattern.

Charger

- Automatic, temperature compensated, charger.
- High capacity, automatic, dust-tight instantaneous transfer relay.
- Low voltage disconnect prevents over discharge of battery. Automatic brownout protection is provided.
- Labor saving AC line latch prevents battery discharge during installation to a non-energized circuit.

Controls

- Red charger monitor LED indicates state of charge of the battery.
- Momentary test switch allows for quick operational check of entire system.

Power Requirements

120/277Vac 60Hz, 0.08/0.04 Amp

OPTIONS

(Add Suffix to Model No.)	Suffix
Damp Location	-DL
Vandal Resistant Screws	-VR
3-Wire Cord & Plug (120V).....	-3CP*
3-Wire Cord and Plug (277V).....	-3CP-277*

*Standard cord is 3 ft. custom lengths available.

ACCESSORIES

(Order as a separate item)

Wire Guard	WG13
Lamp Replacement.....	570.0012

DIMENSIONS

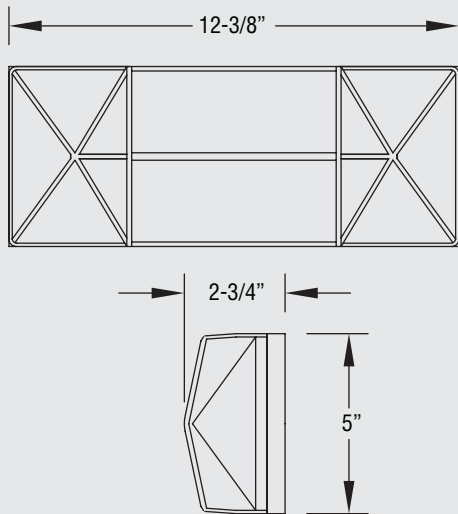

Dimensions are approximate and subject to change

Snap-on housing Self-connecting power plug

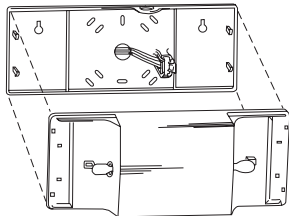

UNIT RATING CHART

Volts	Model No.	*Watts to 87-1/2% of Rated Battery Voltage	
		1-1/2 Hrs.	2 Hrs.
6	IC-2	12	8

*National Electrical Code Specification

ORDERING FORMAT

IC-2

Series

-DL

Option

-DL=Damp Location

See Remote ICR-2 Series on page 78