



Severe Series

NEMA 4X Rated

**Battery Unit and Remote Fixture
for Harsh Environment Applications**

**Impressive State-of-the-Art
Emergency Lighting Illumination**





Introducing the Severe™ Series NEMA-4X Rated emergency lighting units for harsh environment applications

Listed to UL924 standards

The new standard for emergency lighting in adverse environments has arrived.

Completing the Lightalarms family of NEMA-4X rated exit signs and combo units, the Severe™ V Series battery units and ELF650 remote fixtures combine state-of-the-art illumination in a visually appealing package and are designed to perform in a wide range of architectural, commercial and industrial environments where humidity, dust, water infiltration, and the risk of vandalism are specification criteria.

The Severe Series of NEMA-4X Rated emergency lighting sets impressive new performance levels for center-to-center lighting photometrics, illuminating an egress path up to 70-feet long and 3-feet wide (using 2-20W MR16-IR lamps). Over 20-feet further than competitive units!

For complete photometric data, refer to the back cover of this brochure.

Applications

- Hosedown areas / car washes
- Food processing / preparation facilities
- Marine locations
- Chemical plants
- Schools and other public facilities
- Parking garages
- Transit platforms
- Sports arenas / swimming pools
- Security areas / prisons
- Warehouse and cold storage facilities
- Heavy industrial facilities
- Architectural, commercial and retail areas

Certifications

- Certified to meet UL924 standards
- 90 minutes of emergency operation
- NEMA-4X Rated for high abuse areas, wet locations and cold weather (-40°C/-40°F) applications
- NSF Rated for use in food processing plants

Features

- Battery units and remote fixtures deliver unsurpassed pathway illumination – up to 70 feet, center-to-center (see photometric data on back cover)
- Fully gasketed enclosures prevent water infiltration
- Vandal-resistant enclosures - resist dents, peeling and corrosion
- All units come with tamper-proof screws and bits
- UV resistant enclosures
- Choice of colors – mist-white, black and gray
- Continuous self-diagnostic monitoring and monthly self-testing
- Fully automatic, solid state charger
- Non-obtrusive magnetic test switch



NEMA-4X



PATENT PENDING

Severe ELF650 Series

NEMA-4X Rated Remote Fixture



Dimensions

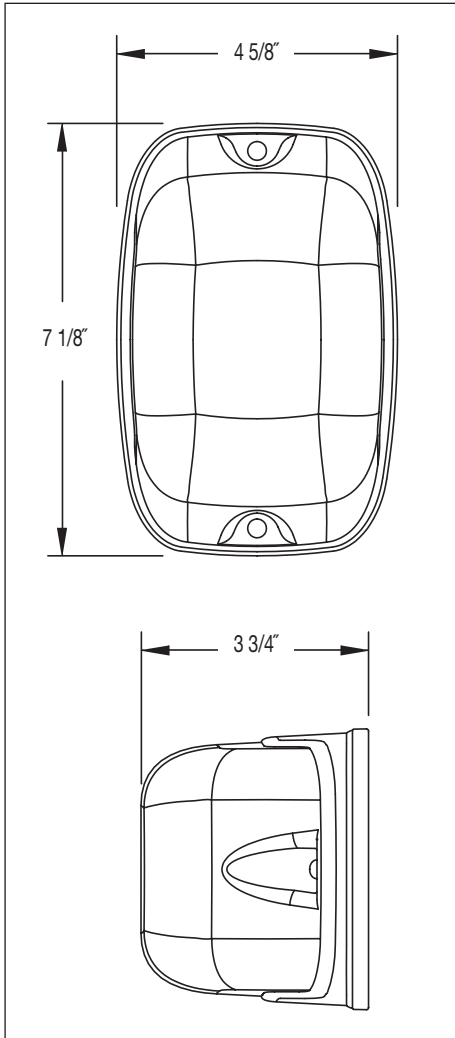

Features

- Listed to UL924 standards
- Delivers unsurpassed path of egress illumination – up to 70 feet, center-to-center when using 2-20W MR16-IR lamps (see photometric data on back cover)
- Fully gasketed cast aluminum back plate, with clear polycarbonate cover – NEMA-4X Rated
- UV and impact resistant cover
- Choice of three colors: mist-white, black or gray
- Choice of single or double head models
- Available in 6, 12 and 24 Volt models with various wattages
- High efficiency MR16 lamps up to 20W-IR or 5W MR16 shape white LED option
- Easy installation on four-inch octagonal box
- Tool-less lamp aiming
- Easy lamp replacement
- Comes standard with tamper-proof screws and bit
- NSF Certified for food processing plants
- Also available as a battery unit. Refer to Severe™ V Series



NEMA-4X



PATENT PENDING

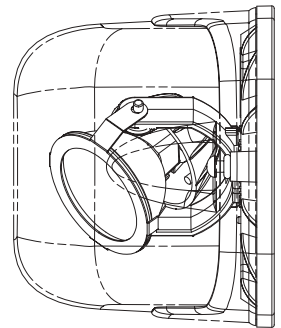
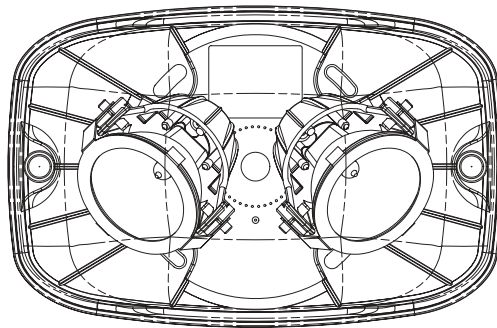

Ordering Information

Series	Lamp Type/Wattage	Color	Voltage
ELF650= single NEMA-4X	/M6= MR16, 6W (6V only)	-M= mist-white	6= 6V
ELF650D= double NEMA-4X	/M10= MR16, 10W (6V only)	-B= black	12= 12V
	/M12= MR16, 12W (12V, 24V only) Flood	-G= gray	24= 24V
	/M20= MR16, 20W (12V, 24V only) Flood		
	/L5= LED, 12V-5W (12V only)		

EXAMPLE: ELF650/M12-M 12



**UNRIVALLED PATH OF EGRESS ILLUMINATION –
UP TO 70 FEET CENTER-TO-CENTER
WITH 2-20W MR16-IR LAMPS**
(see photometric data on back cover)



Battery Unit Severe™ V Series

- Fully gasketed cast aluminum back plate with clear, UV resistant polycarbonate cover
- Tool-less MR16 swivel assembly provides precise beam control
- Non-obtrusive magnetic test switch
- Long-life, maintenance-free sealed Lead-Calcium or Nickel-Cadmium battery
- Choice of MR16 halogen lamps: 6V/12V, from 6W to 20W-IR
- Also available in 5W, MR16 shape white LED lamps (lamp consumes 5W and includes a 3W white LED)
- Mounting: wall, strut or pole mount
- Unit emergency power: up to 54W
- Suitable for cold weather applications — -40°C/-40°F (add suffix -CW4)
- Choice of three different colors: mist-white, black and gray



Remote Fixture Severe™ ELF650 Series

- Choice of single or double head models
- Fully gasketed cast aluminum back plate, with clear, UV resistant polycarbonate cover
- Full range of MR16 halogen lamps of 6, 12 and 24V from 6W to 20W-IR
- Also available in 5W, MR16 shape white LED lamps (lamp consumes 5W and includes a 3W white LED)
- Choice of three different colors: mist-white, black and gray



SevereTM V Series

NEMA-4X Rated Battery Unit

Dimensions

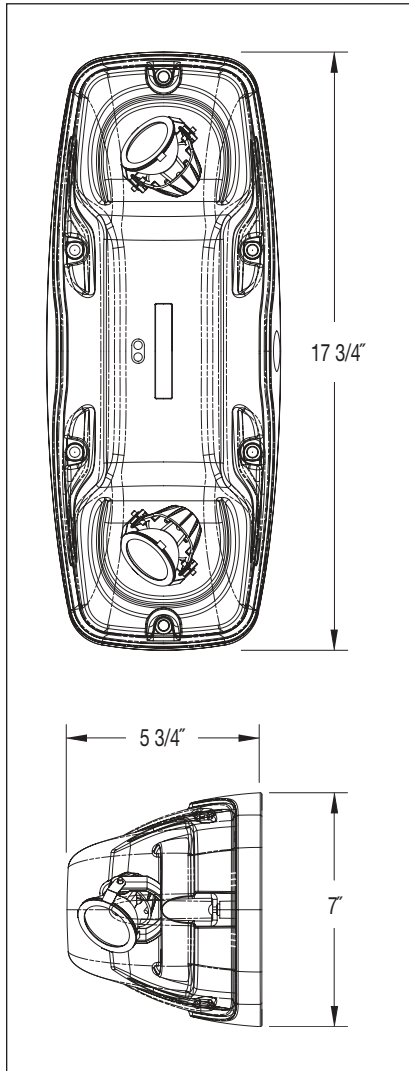

Features

Standard

- Listed to UL924 standards
- Delivers unsurpassed path of egress illumination – up to 70 feet, center-to-center when using 2-20W MR16-IR lamps (see photometric data on back cover)
- Fully gasketed cast aluminum back plate with clear polycarbonate cover – NEMA-4X Rated
- Choice of three colors: mist-white, black or gray
- Comes standard with non-audible advanced diagnostic charger board, 15 minute time delay and lamp disconnect
- Audible warning and time delay functions can be enabled or disabled during installation
- Micro-controller diagnostic system tests, detects and indicates battery, charger circuitry or MR16 lamp failures
- Non-obtrusive magnetic test switch
- High efficiency MR16 lamps, up to 20W-IR or 5W MR16 shape white LED option
- Long-life, maintenance free sealed Lead-Calcium battery (+25°C/+77°F)
- Units with Nickel-Cadmium batteries are listed for damp and wet locations (+10°C to +40°C / +50°F to +104°F)
- 1/2" rigid conduit entry on top and back
- Can be installed on 4-inch junction boxes
- Comes standard with tamper-proof screws and bit
- Standard 120/277Vac input voltage
- NSF Certified for food processing plants
- Also available as a remote fixture. Refer to Severe™ ELF650 Series

Optional

- Universal bracket (for mounting on poles, I-beams or strut metal framing)
- Cold weather option (-40°C to +40°C / -40°F to +104°F). Call factory for other temperature ranges



NEMA-4X



PATENT PENDING

Accessories (order as a separate item)

Additional bit for tamperproof screws TPB

Universal bracket (for mounting on poles, I-beams or strut metal framing) PMK

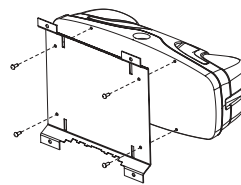

PMK Kit (screws included)

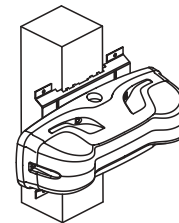

Beam Mounting

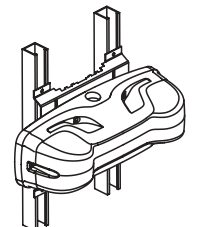

Strut Mounting

Ordering Information

# of Heads	Series	Lamp Type/Wattage	Color	Charger	Options
2= 2 heads	VG1= 6V - 18W, Lead-Calcium	/M6= MR16, 6V-6W	-B= black	-D= Improved Diagnostics non-audible (standard)	Blank= no options
	V12G1= 12V - 24W, Lead-Calcium	/M12= MR16, 12V-12W	-G= gray		-CW4= cold weather *
	V12N1= 12V - 24W, Nickel-Cadmium	/M20 = MR16-IR, 12V-20W	-W= mist-white	-DA= Improved Diagnostics audible	(-40°C to + 40°C / -40°F to + 104°F)
	V12G2= 12V - 36W, Lead-Calcium	/L5= LED 12V-5W			
	V12G3= 12V - 54W, Lead-Calcium				

* Only available with V12G1 & V12G2

EXAMPLE: 2V12G2/M12-B-D

Severe™ Series

Photometrics

The Lightalarms NEMA-4X Series of emergency lighting sets an impressive new standard for center-to-center path of egress illumination.

Battery units and remote fixtures illuminate an egress path up to 70-feet long, center-to-center, and 3-feet wide (using 2-20W MR16-IR lamps).

Photometric data based on a 7.5-foot mounting height, minimum 80-50-20 reflectance values and 12V 20W lamps.



3D image showing installation of two V Series battery units and a combo unit in an industrial application under normal lighting conditions.



3D image lighting rendering showing installation of two V Series battery units and a combo unit in an industrial application under emergency lighting conditions.

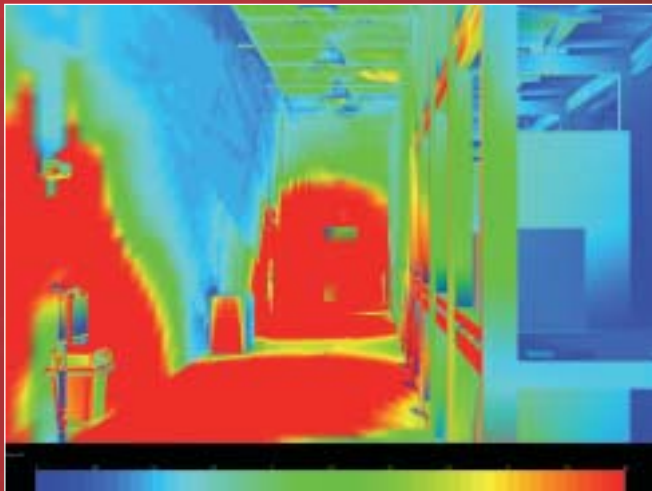

3D light level coloured scale image showing egress illumination pattern generated by two V Series battery units and a combo unit.

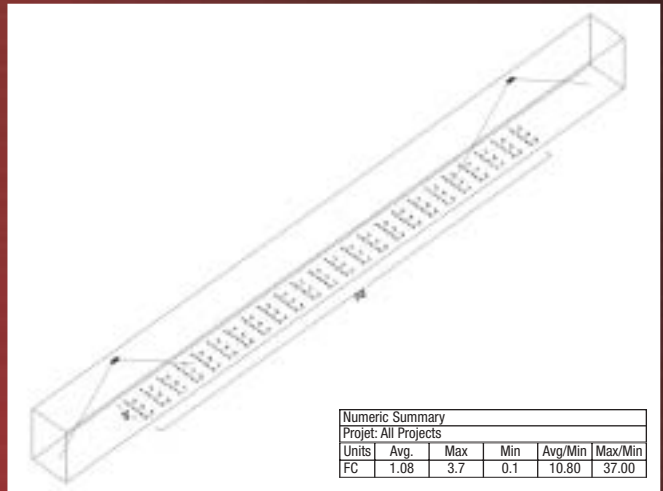

ISO curve on a point-by-point grid of two V Series battery unit with 2-20W MR16-IR lamps per unit.

NOTE: Photometric results shown are based on a simulation using the AGI32 software with a 1 foot-candle average and 0.1 foot-candle minimum with a 40:1 maximum-minimum ratio. Lightalarms assumes no responsibility for local requirements or specific project variables. This is a guideline to be used as a design aid, not a guarantee of any code compliances.

Thomas & Betts