

Series "Grande" - Thermoplastic LED Combo Sign

Self-Powered LED model

IMPORTANT SAFEGUARDS

When using electrical equipment, basic safety precautions should always be taken including the following:

READ AND FOLLOW ALL SAFETY INSTRUCTIONS

1. Do not use outdoors.
2. Do not let power supply cords touch hot surfaces.
3. Do not mount near gas or electric heaters.
4. Equipment should be mounted in locations and at heights where it will not readily be subjected to tampering by unauthorized personnel.
5. The use of accessory equipment not recommended by the manufacturer may cause an unsafe condition.
6. Do not use this equipment for other than intended use.
7. All servicing should be performed by qualified service personnel.

SAVE THESE INSTRUCTIONS

Installation Instructions

1. Turn off AC power.
2. Route AC unswitched circuit of rated voltage into electrical box and leave 6" of wire length.
3. Remove face plate screws (only for some models). Remove the combo front door using a coin or a screwdriver at the top or bottom of the door. Arrows on the frame point towards the front door (See Fig. 2).
4. Determine the mounting position (wall or ceiling). Note: a canopy(6) is required for ceiling mount.
5. Our system can accept input voltages of 120 VAC, 277 VAC. Therefore, connect the black (120 VAC) or orange (277 VAC) and white (common) leads to the building utility. Connect the green wire to the ground. Unused primary wire must be insulated to prevent shorting.

Wall mounting

No canopy required. Remove the battery(s) with wires. With the help of flat head screwdriver, knock out the proper hole pattern on the back cover, including the center hole, to mount to a standard junction box as well as the two wall anchoring points (See Fig. 2). Install means to anchor unit in line with "Wall anchoring points". Feed the AC supply leads (and DC leads for remote lamps if applicable) around inside the housing, through the plastic conduit and out through the center hole and make the proper connections (See Fig. 6). Feed the excess wire into the junction box. Secure the back plate to the wall at wall anchoring points using wall mount screws(16), then to the junction box using the junction box screws(7). Proceed to step 6.

Conduit entry mounting

Remove knock-out for the conduit entry located on the top of the central housing (See Fig. 2).

Secure unit to the wall following "Wall mounting" instructions and make appropriate connections.

Ceiling mount

Canopy required. Remove the battery(s) with wires connected. Attach the spider plate to electrical box with the junction box screws(7). Remove the

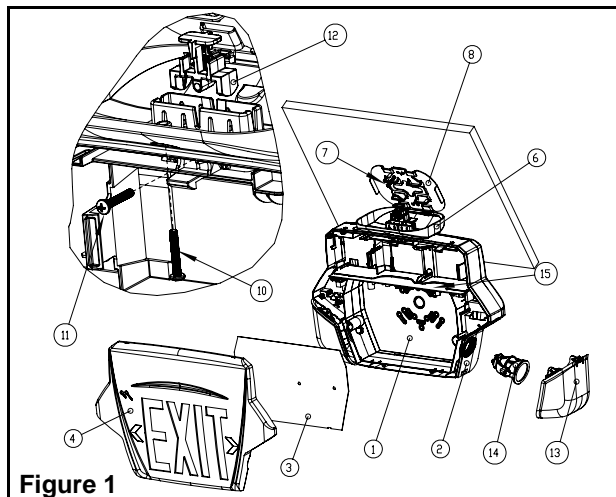

Figure 1

Part List

- | | |
|---------------------------------------|--------------------------------------|
| 1. Back Plate | 9. Junction Box |
| 2. Central Housing | 10. Canopy Plate Screw |
| 3. Diffuser Panel | 11. Canopy Housing Screw |
| 4. Face Plate | 12. Canopy Lock |
| 5. Hole Plug for Canopy | 13. Lens |
| 6. Canopy | 14. Lamp Assembly |
| 7. Junction Box Screws (not Provided) | 15. PCB |
| 8. Spider Plate | 16. Wall Mount screws (not Provided) |

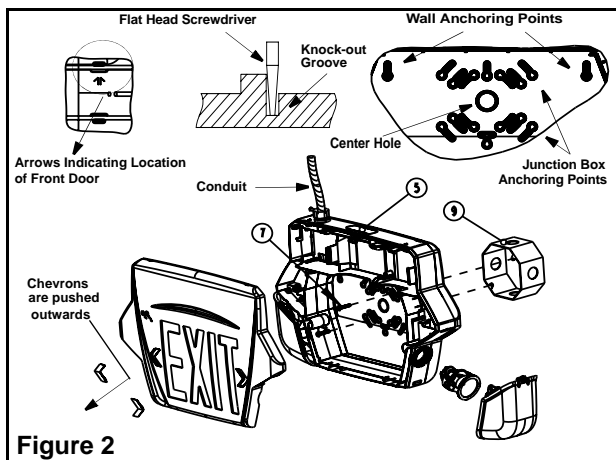

Figure 2

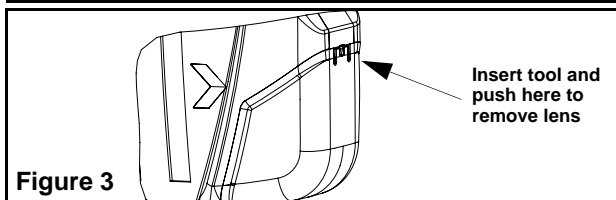

Figure 3

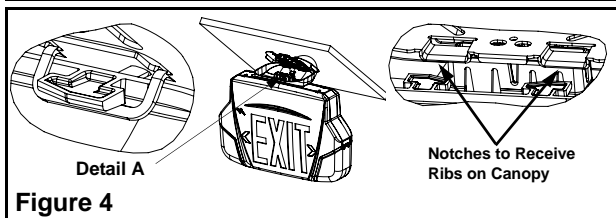

Figure 4

hole plug(5). Feed AC supply leads (and DC leads for remote lamps if applicable) out through top opening and then through canopy. Remove the canopy lock(12). Snap the canopy into the opening on top of frame. Reinstall the canopy lock into the canopy. Secure the assembly with canopy housing screw(11) (See Fig. 1). Make the proper wire connections. The "Quick-install" canopy is equipped with ribs allowing you to hang the unit spider plate to facilitate wiring (See Fig.4). Feed the excess wire into the junction box. Unhook unit and slide ribs on canopy into designated notches on the spider plate (See Fig. 4). Secure the canopy to the junction box using the canopy screws provided(10).

6. Install battery(s) and wires.
7. Remove the appropriate chevron(s) on the exit door by holding sign with both hands. Push chevrons from the inside with thumb (See Fig. 2). You will need to unsnap the diffuser panel to do so.
8. Connect battery "T Connector" to PCB ("B" connection) (See Fig. 6).
9. Remote lamp(s) connection : Feed external DC+ & DC- wires through unit and connect to internal wires using wire nuts provided (See Fig. 6).
10. Reinstall combo door(s). Fasten screws (only for some models).
11. Remove lenses (See Fig. 3) and discard plastic bags. Adjust the lamps in appropriate position. Re-install both lens.
12. Energize AC. Sign will illuminate.

Note — DC input voltage is 6 or 12 volts depending on unit type.

Unit testing

Manual testing

Press test switch. Legend will flicker, but remain lit. On release, external green LED will illuminate, and automatic charger will restore battery to full charge.

Automatic testing and diagnostics

The automatic testing and diagnostic function includes a micro-controller which self-tests the unit on a monthly basis and identifies as well displays failures of the electrical components: battery, battery charger, lamps, LEDs.

Self-test

The self-test is performed every months for 1 minute, every 6 months for 30 minutes, and annually for 90 minutes.

Diagnostic function

The diagnostic function uses an external green LED indicator. Service is required if the green LED blinks indicating that an alarm condition is detected (See Fig. 7).

o	Green	Steady On	AC On
o	Red	Steady On	Battery Disconnect
-o	Red	Blinking	Battery Failure
o-o	Red	Two Blinks	Charger Failure
o-o-o	Red	Three Blinks	Lamp Failure
o-o-o-o	Red	Four Blinks	LED Failure

For Nexus models, refer to "Nexus addendum".

Units with automatic testing are shipped "non-audible". If you wish to make the unit "audible" simply re-orient the jumper "JP5" as shown in figure 8.

Maintenance — None required. If AC supply to the unit is to be disconnected for 2 months or more, the battery must be disconnected.

Note — NIMH (Nickel Metal Hydride) batteries are shipped discharged and need to be connected to an AC supply for 10 minutes before start-up test procedure, 24 hours to charge to meet a 30 minute discharge or 96 hours to reach full charge.

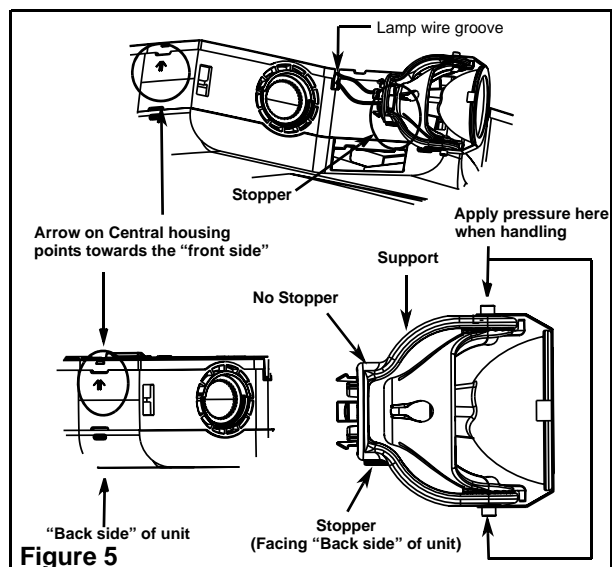

Figure 5

Assembly steps:

1. Remove lamp assemblies from plastic wrapping.
2. Place wires in respective grooves on the central housing.
3. Align and snap in place with "stopper" oriented per Figure 5.
4. Handle assemblies by applying a pressure on either end of the support per Figure 5.

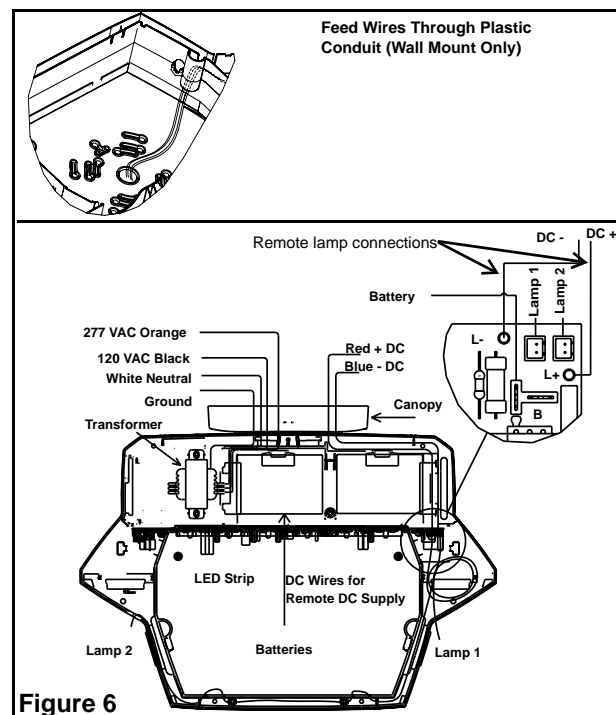

Figure 6

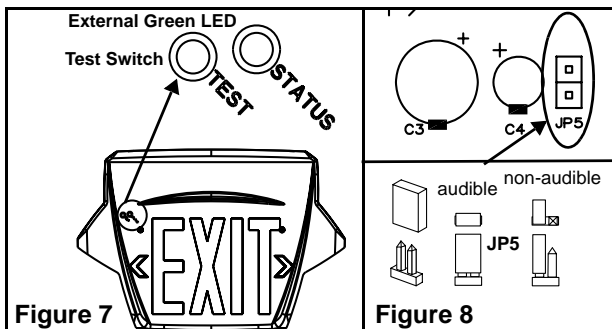

Figure 7

Figure 8