



SEVERE™ ELF650 SERIES

TYPE: _____
 CATALOGUE #: _____
 NOTES: _____



Emergency Lighting for Remote Fixtures

Nema 4X Rated, double head complete with gasketed cast aluminum backplate and clear UV impact resistant case.

Single lamp and double lamps available



NEMA-4X

DESIGN PATENT
US D558,9105

General Information

The **Severe™ ELF650 Remote** Emergency Lighting fixture will help change the way typical emergency lighting remote units are perceived. It is designed and engineered with style in mind and sets new standards for emergency lighting in today's toughest environments. It can be equipped with one or two MR16 lamps for 6, 12 or 24Vdc applications. The innovative, fully adjustable, emergency heads covered by a sealed clear lens is an industry first and offers a visual appealing design that makes it ideal for any commercial or industrial application.

Whether it is a large warehouse, heavy-duty plant or food processing installation, the Severe ELF650 Remote Unit, rated NEMA 4X, is the solution for all your industrial remote emergency lighting fixtures. Its tamper-proof revolutionary compact design makes it also suitable for commercial applications as well as for schools and public facilities. The MR16 emergency lights are protected by a UV-stabilized clear polycarbonate cover, which is installed with stainless steel tamper-proof screws. The housing is available in 3 colors: mist white, black or gray.

Mounting: Direct to 4" octagonal electrical box

Lamps: Series MR16 (M Series)

Standard Features

The **Severe™ ELF650 Remote**, Nema 4X rated, remote fixtures have a fully gasketed cast aluminum back plate, with a clear UV and impact resistant cover. This remote fixture delivers unsurpassed path of egress illumination - up to 70 feet, center-to-center when using 2-20W MR16-IR lamps. The ELF650 is available in single or double head models with the option of highly efficient MR 16 lamps or the 5-watt MR16 white LED lamp. Easy lamp replacement, tool-less lamp aiming and easy installation on a four-inch octagonal box all make this remote the perfect choice for any environment. Comes standard with tamper-proof screws and bit. NSF Certified for food processing plants. Choice of three colors, mist white, black or gray.

Unit Warranty*

Entire unit (excluding lamps) carries a 3-year full warranty.

*Subject to proper installation and maintenance

Dimensions

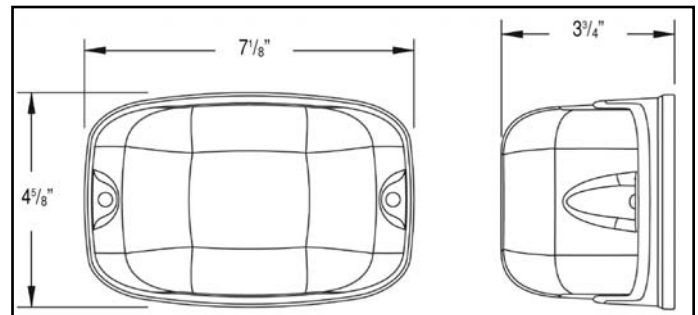

Ordering Information

Example: ELF650/M6-M6

Series	Lamp Type/Wattage	Color	Voltage
ELF650 = Single Nema 4X	/M6 = MR16, 6 watts (6V only)	-M = mist white	6 = 6 volt
ELF650D = Double Nema 4X	/M10 = MR16, 10 watts (6V only)	-B = black	12 = 12 volt
	/M12 = MR16, 12 watts (12V only)	-G = gray	24 = 24 volt
	/MH20 = MR16, - 20 watts-IR (12V only)		
	/M20 = MR16, 20 watts (24V only)		
	/L5 = LED, 12V - 5 watts (12V only)		



Thomas & Betts