

# XVHZ Series – Severe Exit Sign

## AC/DC & Self-Powered Models

### IMPORTANT SAFEGUARDS

When using electrical equipment, basic safety precautions should always be followed including the following:

### READ AND FOLLOW ALL SAFETY INSTRUCTIONS

1. Do not let power supply cords touch hot surfaces.
2. Do not mount near gas or electric heaters.
3. Use caution when handling batteries. Avoid possible shorting.
4. Equipment should be mounted in locations and at heights where it will not readily be subjected to tampering by unauthorized personnel.
5. The use of accessory equipment not recommended by the manufacturer may cause an unsafe condition.
6. Do not use this equipment for other than intended use.
7. All servicing should be performed by qualified service personnel.

### SAVE THESE INSTRUCTIONS

#### Installation Instructions

1. Turn off unswitched AC power.

##### Ceiling Mount

- a. Remove j-box assembly from carton. Remove j-box cover from j-box assembly and retain securement screw.
- b. Install junction box and route unswitched AC circuit wires into the junction box and leave 6" of wire length.
- c. Remove lens, exit panel and diffuser panel on the front of the unit (use the supplied bit to remove the tamper-proof screws).
- d. In order to access the knockouts of the frame, remove the 4 electronic module screw(s) holding the electronic module to the frame and separate them (see fig.2).
- e. Remove knockout on top of the frame. Determine which holes in the exit frame will be used for mounting (see fig.1). Support frame by two blocks of wood, maximum one inch apart. Strike knockouts with a hammer and screwdriver. Clear holes of burrs to allow proper assembly of nipple/wire assembly.
- f. Secure j-box cover to the frame using the provided nut.
- g. Reassemble the electronic module inside the frame.

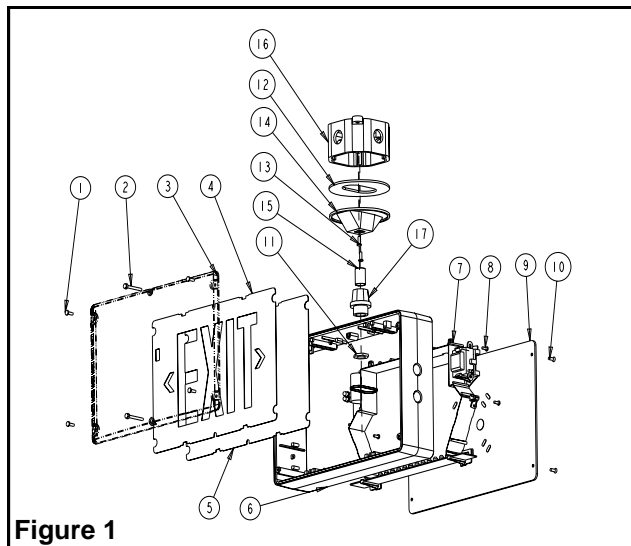

Figure 1

#### Part List

- |   |                                       |
|---|---------------------------------------|
| 1. Tamper-proof screws short (4 per lens) | 9. Backplate (single face sign)       |
| 2. Tamper-proof screws long (2 per lens)  | 10. Backplate tamper-proof screws (4) |
| 3. Lens                                   | 11. Lock-nuts (2)                     |
| 4. EXIT panel                             | 12. Junction box gasket               |
| 5. Diffuser panel                         | 13. Junction box screws(2)            |
| 6. Frame                                  | 14. J-box Cover                       |
| 7. Electronic module                      | 15. Nipple                            |
| 8. Electronic module screws (4)           | 16. Junction box                      |
|   | 17. Hub                               |

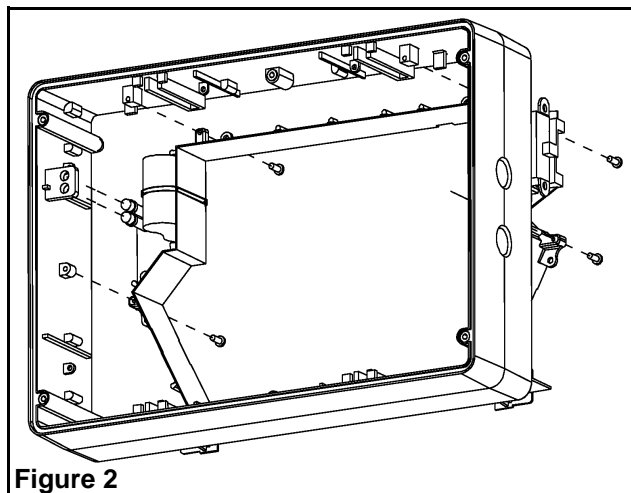
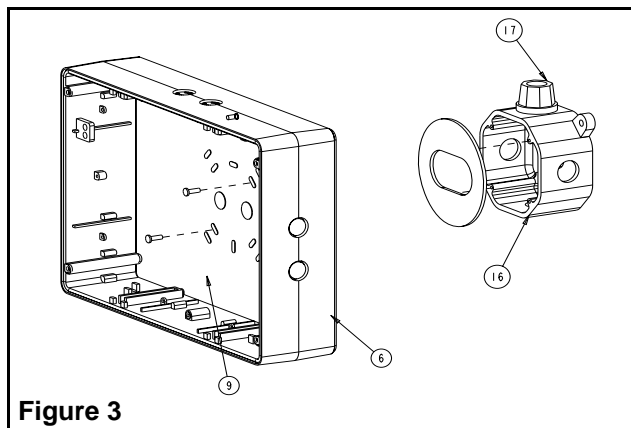

Figure 2

### Wall Mount (Single Face Model Only)

- a. Remove j-box assembly from carton. Remove j-box cover from j-box assembly, install Hub on j-box and retain securement screw.
- b. Remove the backplate(9) from the packaging. Determine the proper knockouts to remove for mounting to the junction box (see fig.3).
- c. Support area around knockouts with two blocks of wood. Strike knockouts from the inside with a hammer and a screwdriver.
- d. Reinstall the backplate to the frame using the 6 tamper-proof screws (use the supplied bit).

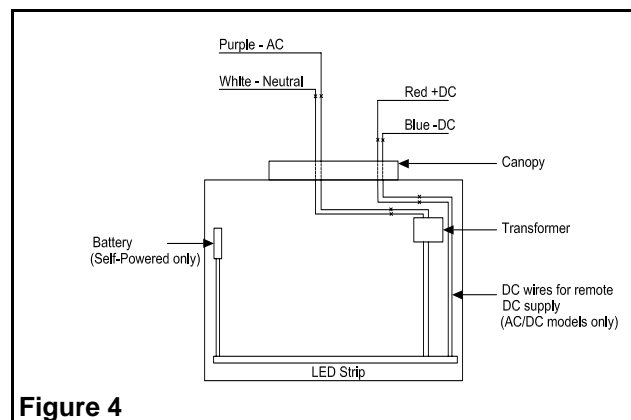

**Figure 3**

2. **Electrical connections:** Connect one end to the transformer leads, inside the enclosure, and the other end, to AC line voltage inside the junction box. Connect the white lead to neutral and the purple lead to AC line voltage (the input is universal 110 to 347 VAC). (See fig. 4). Connect the ground(green wire) to the junction box.

**Optional:** For AC models used with DC remote power. One end connects to the LED-STRIP leads, inside the enclosure, and the other end to DC input inside the junction box. Connect the red lead to positive, and the blue lead to the negative of the remote DC input (See fig. 4).

3. **For ceiling mount:** Mount the frame and j-box cover assembly to junction box by using the provided securement screw.  
**For wall mount:** Attach the frame(6) to the junction box, using the junction box supplied screws. Install 2 stem washers to ensure bonding.
4. Reinstall the diffuser and the EXIT panel (if required, remove the appropriate chevron).
5. Install the lens by using the 6 tamper-proof screws.  
**The tamper-proof screws should be equally torqued to approximately 5 lbs-in (0.6 N-m).**
6. Energize AC. Sign will illuminate.



**Figure 4**

### Manual Testing (Self-Powered Models)

Operate the magnetic “test switch” by holding the provided magnet underneath the unit where indicated on the frame. The AC pilot lamp will go out, the legend will flicker, but remain lit. Remove the magnet. The AC pilot light will turn on, the legend will flicker but remain lit.

### Automatic Testing (Self-Powered Models)

The unit will perform an automatic self-test of 30 seconds every 30 days, 60 second every 60 days and a 90 minute self-test once a year.

### Nexus models

Refer to figure 5 for the wiring of Nexus models.

These units can accept an input voltage of 120 or 277 VAC:

**120 VAC** — Connect the black (120 VAC) lead and white (neutral) lead to the building utility. Insulate the red wire.

**277 VAC** — Connect the orange (277 VAC) lead and white (neutral) lead to the building utility. Insulate the black wire.

Feed excess wire into the junction box.

Leave as much space as possible between the live voltage cabling and the unsheathed low voltage data cabling.

Run the double insulation of data cables past the line cabling section and only strip back the last 30mm of the data cable sheathing.

### Automatic Diagnostics (Self-Powered Models)

There are three diagnostic indicators: one external and two internal. Unit must be opened to gain access to internal indicators.

External: General alarm, “Service Required”. The LED will blink if any alarm condition is detected (see fig. 6).

Internal: Battery Alarm & Charger Alarm. Steady ON if alarm condition exists (See fig. 7).

**Normal operation, No fault** — “Service Required” is OFF and one of the two internal LED blinks, showing that the micro controller is active.

**Faulty operation** — “Service Required” blinks.

Battery Alarm ON, Charger Alarm OFF: Check battery or replace battery.

Battery Alarm ON, Charger Alarm ON: Check LED strip.

Battery Alarm OFF, Charger Alarm ON: Check charger circuit.

### Nexus models

Nexus models use two local indicators. One is a green LED for AC pilot lamp. The other is a tricolor LED (Service) which identifies and displays the Nexus status. The table below describes each status:

**Nexus Tricolor LED** — Status table

	<b>Uncommissioned</b>	<b>Commissioned</b>
Normal	Red/Off pulsing	Green steady
Under test	N/A	Green/Off pulsing
Wink mode	Yellow-orange/(red or off) pulsing	Yellow-orange/Off pulsing
Neuron faulty	Red Steady	Red steady
Power fail	Off	Off
Battery disconnected	N/A	Off

### Maintenance (All Models)

None required. If AC supply to the unit is to be disconnected for 2 months or more, the battery must be disconnected, Self-Powered Models only.

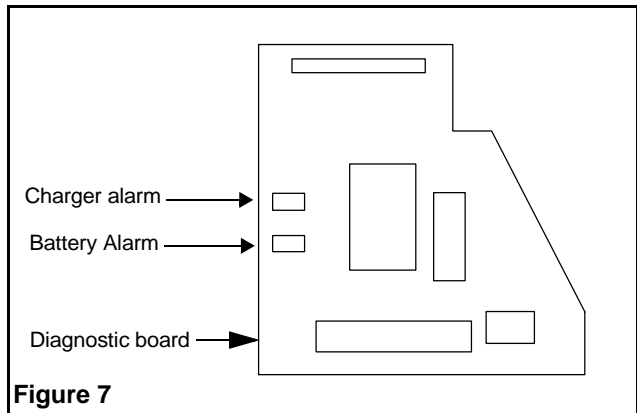
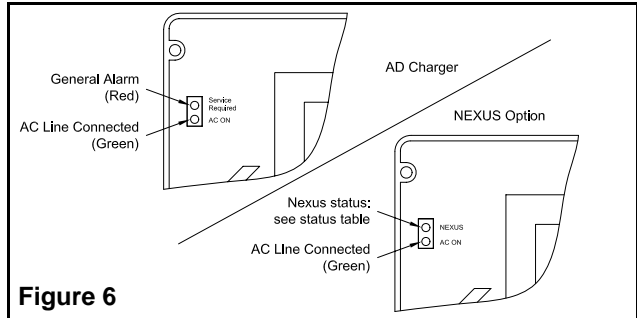
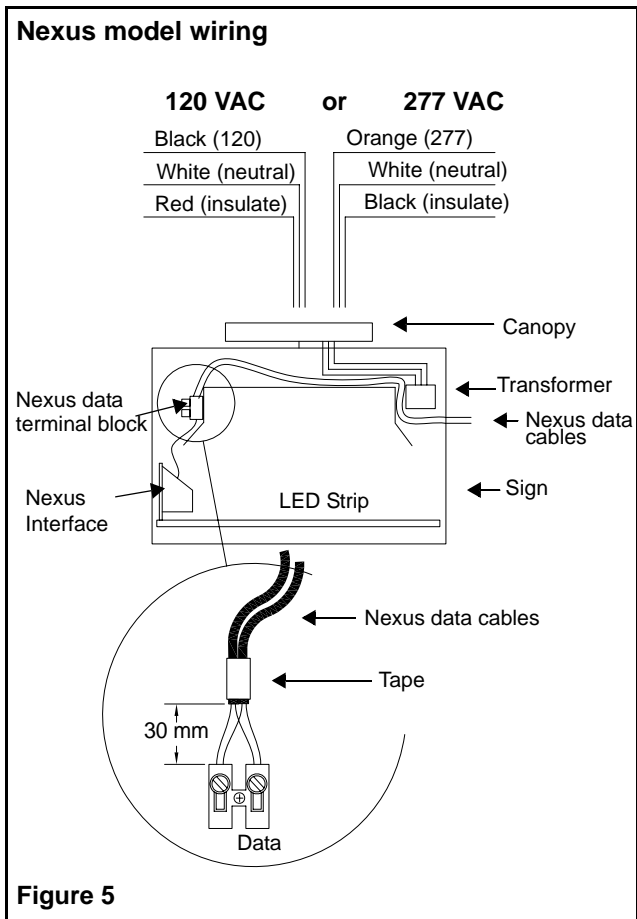

## Double Face Installation

### Installation Instructions

1. Turn off unswitched AC power.
  2. Remove backplate by unscrewing the four tamper-proof screws holding the backplate to the frame (see fig. 8)
  3. Install the four backpanel retention screws (see fig. 9)  
*Note: The four screws may already be installed.*
  4. Install the diffuser panel by snapping the top edges under the two top retention screws and then snapping the bottom edges under the two bottom retention screws (see fig.10).
  5. The EXIT panel installs in the same manner (if required, remove the appropriate chevron).
  6. Install the lens by using the 4 short and 2 long tamper-proof screws (see fig.11).
- The tamper-proof screws should be equally torqued to approximately 5 lbs-in (0.6 N-m).**
7. Energize AC. Sign will illuminate.

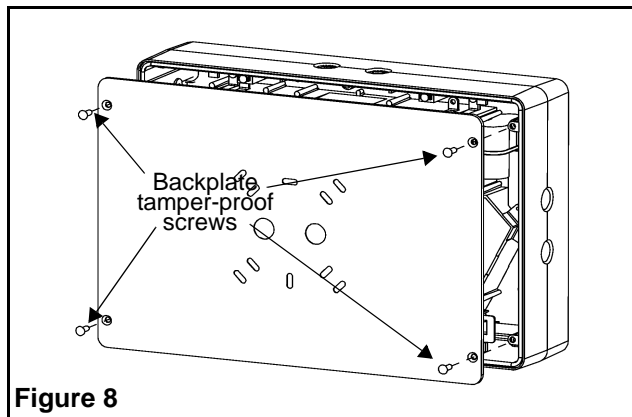

Figure 8

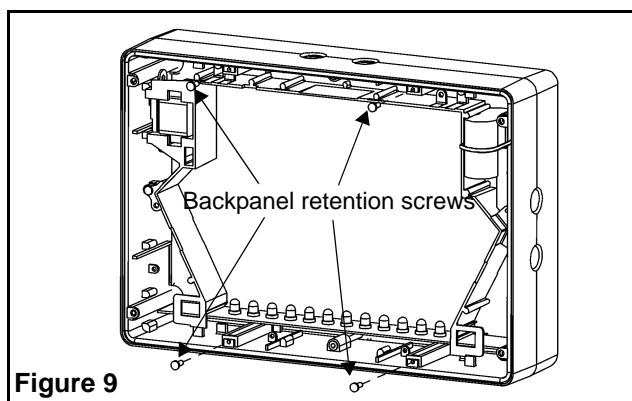

Figure 9

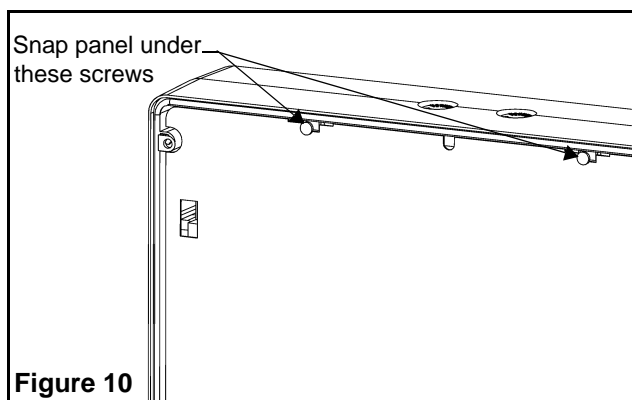

Figure 10

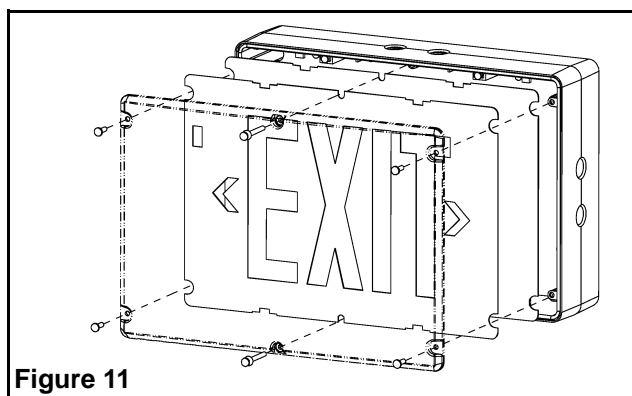

Figure 11