

Camray - Emergency Lighting

IMPORTANT SAFEGUARDS

When using electrical equipment, basic safety precautions should always be followed including the following:

READ AND FOLLOW ALL SAFETY INSTRUCTIONS

1. Do not let power supply cords touch hot surfaces.
2. Do not mount near gas or electric heaters.
3. Use caution when handling batteries. Avoid possible shorting.
4. Equipment should be mounted in locations and at heights where it will not readily be subjected to tampering by unauthorized personnel.
5. The use of accessory equipment not recommended by the manufacturer may cause an unsafe condition.
6. Do not use this equipment for other than intended use.
7. All servicing should be performed by qualified service personnel.

SAVE THESE INSTRUCTIONS

Installation Instructions

1. Turn off building electrical emergency circuit.
2. Remove the backplate by inserting a flat head screwdriver into the tab, located on the top, and twisting (see fig. 1).
3. Locate the quick connect connector, on the housing and disconnect it and put aside.
4. Choose the proper mounting solution below and continue to step 6.

Junction box mounting

- a. For standard junction box mounting, knock out the desired hole pattern in the backplate. Do the electrical connections as shown on point 5. Route the quick connect through the large knockout and mount the backplate to the junction box.

Conduit entry mounting

- a. Remove plug on the back plate and knock out the desired hole pattern in the back plate to secure the unit on the wall if required. Install the conduit and supply wires. For wet location: install a liquid tight fitting with teflon tape. Take wire nuts provided with the units. Bigger wire nuts might interfere with internal components.

5. Electrical connections

Attach to the unswitched building electrical emergency circuit. Make the proper connections.

120 VAC — Connect the black (120 VAC), white (neutral) and ground(green) leads to the building utility. Insulate orange wire.

277 VAC — Connect the orange (277 VAC), white (neutral) and ground(green) leads to the building utility. Insulate black wire.

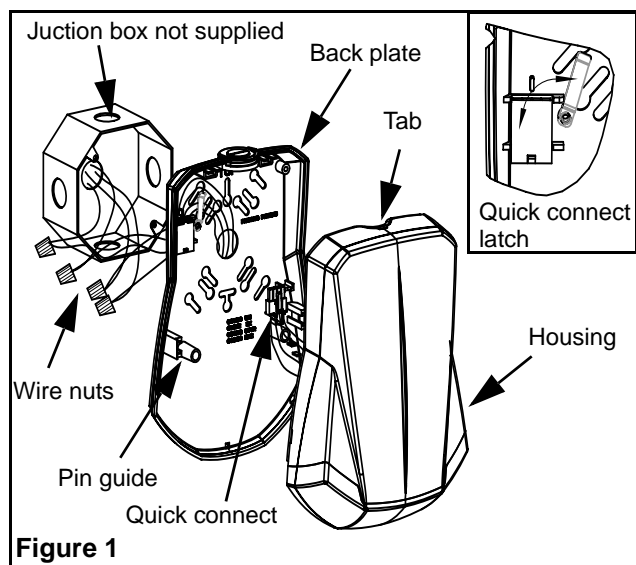

Figure 1

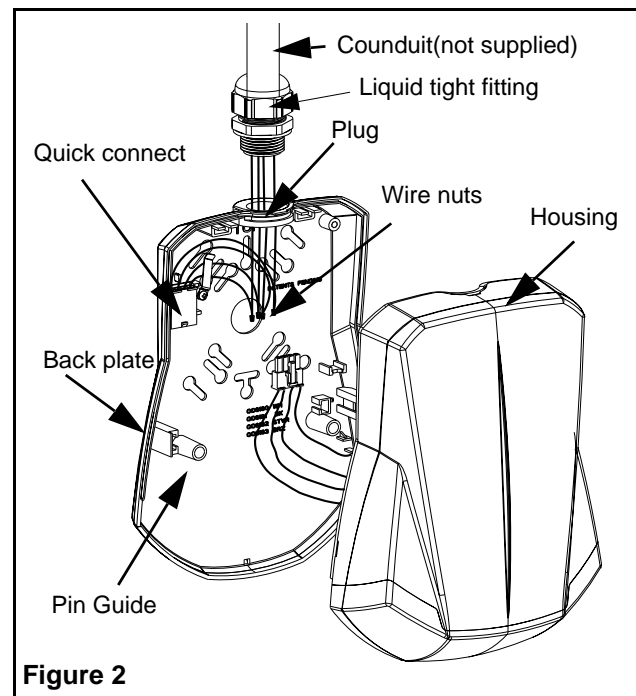

Figure 2

<i>Load</i>	<i>Wire Color</i>
Neutral	White
120 Volt	Black
277 Volt	Orange
Ground	Green

Figure 3

Remote - Connect the red (+) and the blue (-) leads to the DC input voltage of building utility. DC input voltage is indicated on the unit. It has to be compatible with the building electrical emergency circuit.

6. Place the quick connect in the slot and lock in place with the latch as shown in figure 1.
7. AC must be off when mating quick connect. Mate the AC connector on the unit with the connector from the building AC service. Take the Housing and make sure the battery is connected to the board.
8. Reinstall the housing on the back plate. The housing is aligned to the pack plate with the two guides pin. In order to ensure proper snaps, maintain the housing parallel to the wall. Press together until it snaps. If it doesn't snap properly, try again making sure you maintain housing parallel to the wall. For conduit entry mounting, make sure the wire nuts provided with the unit have been used. Bigger wire nuts might interfere with internal components.
9. Energize AC. The AC pilot indicator, located under the cover, will illuminate.

Testing

Press test switch. The emergency lamps will illuminate. When switch is released, lamps will go off. Allow unit to charge for 24 hours before initial testing. For self-diagnostics/self-test circuitry, you need to press the test switch again to turn off the lamps.

Instructions for self-diagnostics/self-test circuitry

1. Install units according to previous Instructions.
2. As soon as AC power is supplied to fixture, the unit will automatically initiate a self-test and self-diagnostic test as follow:
 - a. Verify battery disconnection, charger board failure, lamps failure and battery failure
 - b. One-minute self-testing every month.
 - c. 30 minutes self-testing every 6th month after installation.
 - d. 90 minutes self-testing every 12th month after installation.
3. Dual color LED lamp indicator shows the following status:
 - a. Green color: AC on/Ready.
 - b. Red color (Service Alert) See figure 4.
4. Transfer time delay (TD option)

This function will keep the power on the emergency lights for a period of 5, 10 or 15 minutes after the AC power is restored. If the battery goes into LVD before the end of the delay, the power to the lamps is removed and all functions restored. The time delay is activated by a brownout condition or a power failure.

Maintenance

None required.

This equipment is furnished with a low voltage disconnect circuit to prevent damage by over-discharging the battery. However, if the AC supply to the unit is to be disconnected for 2 months or more, the battery must be disconnected.







 green	Steady	AC On
 green	Blinking	Testing Mode
 red	Steady on	Battery Disconnect
 red	One Blink	Battery Failure
 red	Two Blinks	Charger Failure
 red	Three Blinks	Lamp Failure

Figure 4