



Lightalarms



TYPE: _____

CATALOG #: _____

NOTES: _____

Camray Series



Now with white LED normally-on option

Features

Reliability

The **Camray Series** comes complete with a 3-year full warranty (excluding fuses and incandescent lamps).

Unit Data

The **Camray** units are made of durable cast aluminum housing, finished with textured polyester powder coat paint. Four colors are available: off white, black, platinum gray and dark bronze. The vacuum-plated die-cast reflector will last over time. The lens is made of an impact and UV resistant polycarbonate.

The unit can be installed on various Junction boxes with universal mounting pattern. It can also accept a surface mount cable, via the rigid conduit entry provision on the top of the unit.

Lamp information

The **Camray** units are furnished with two high-output Xenon lamps. These lamps, combined with a patent pending reflector, deliver an incredible center-to-center spacing. The reflector has been designed to provide an evenly distributed illumination pattern for corridors, up to 6' wide.

Charger

All self-powered battery units come with a dual-input 120/277Vac, 60Hz. Chargers also include low voltage disconnect to prevent deep discharge, battery lockout to prevent battery drain prior to energizing the utility power, brownout protection which will automatically switch unit into emergency mode if the utility power falls below 80% of nominal and battery reverse polarity protection.

Lead-Calcium Models are equipped with the Pulse Type circuitry that will promote long battery life and excellent performance. This current limiting charger will minimize energy consumption.

Nickel Metal Hydride Models are equipped with the non-audible version of the Improved Diagnostics circuit (IDNA). It will monitor and indicate any of the following failures: battery disconnect, battery, charger and lamp failures. The unit will perform a periodical self-test, of minimum 30 seconds every 30 days, 30 minutes every six months and 90 minutes annually.

Controls or electrical

- Lead-Calcium Models: red LED indicates AC power is on
- Nickel Metal Hydride Models: bi-color LED indicates battery state of charge, test activation and four-state diagnostic status
- Test switch allows for quick operational check of the entire system

Power Requirements

120/277Vac, 60Hz, 0.11/0.05 Amp

Battery Replacement

840.0004-L 6V12W Lead Calcium
 850.0086-L 6V12W, 20W NiMH

Lamp Replacement

570.0213-L 6V6W Xenon
 570.0214-L 6V10W Xenon
 570.0215-L 12V6W Xenon
 570.0216-L 12V10W Xenon

Typical Specification

White LED – Accent Light Camray with dual-mode illumination (optional)

• General

The dual-mode illumination feature enables the Camray to provide lighting not only during power outages, but also in normal conditions. This is achieved with a secondary light source, a long-life, 5-watt power LED lamp dedicated to normal lighting.

When equipped with this feature, the equipment includes two independent circuits, electrically isolated from each other: a standard input for emergency lighting and a secondary input for normal lighting. The secondary input can be connected to a regular AC line that may include an electric switch. The dual-mode illumination option is available with any model of Camray unit:

- = Battery-operated (self-powered): Lead-Calcium (6V 12W), NiMH (6V20W) and NiMH extreme temperatures (6V 12W)
- = DC-remote: 6Vdc or 12Vdc; 2 x 6W or 2 x 10W Xenon lamps

• Electrical

The Camray LED lamp for normal lighting utilizes one five-watt white LED supplied with a simple and robust ballast circuitry.

- = DAC input: dual voltage 120/277Vac, 0.04A, 5W
- = LED lamp operational life: 50,000 hours (till 70% of initial light level)

Specifications For Camray Series

Dimensions are approximate and subject to change.

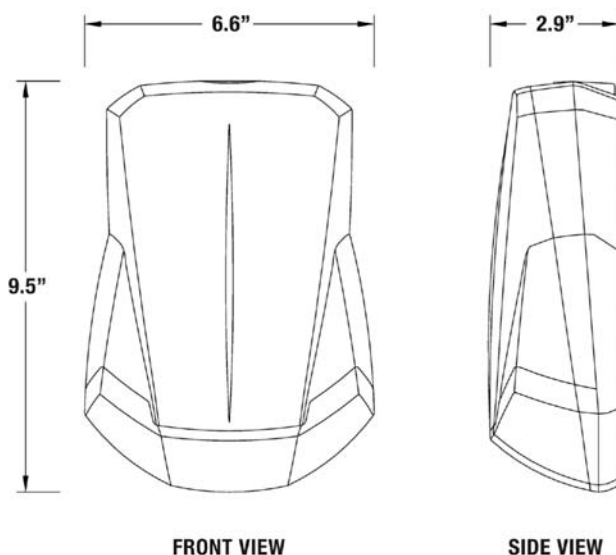

Battery Unit

Example: CAML/LX6-OWT1

Series	Lamp/Wattage*	Color	Options
CAML= 6V - 12W, lead calcium (+20°C to +30°C) Pulse Type charger	/LX6= Xenon 6V 6W /LX10= 6V 10W**	-OW= off white -B= black	-T1= 5 min time delay -T2= 10 min time delay
CAMN= 6V - 12W, NiMH (-20°C to +40°C) comes with improved diagnostic non-audible (IDNA)		-DB= dark bronze -PG= platinum gray	-T3= 15 min time delay -2= dual-mode lighting
CAMN2= 6V - 20W, NiMH (+20°C to +30°C) comes with improved diagnostic non-audible (IDNA)			Note: time-delay available only with IDNA, CAMN and CAMN2 units.
	*Xenon wedge base T3-1/4 **Only available in CAMN2 # other lamps available	Other colors available at a premium. Please consult your sales representative.	Limited Warranty LD-CA battery 3 years NiMH battery 5 years

Remote Unit

Example: CAM/LX6-OW6-2

Series	Lamp/Wattage	Color	Voltage	Options
CAM= remote fixture (-40°C to +60°C)*	/LX6= 6W /LX10= 10W	-OW= off white -B= black -DB= dark bronze -PG= platinum gray	6= 6V 12= 12V	-2= dual-mode lighting
Outdoor remote *Option Dual-Mode Lighting: (-40°C to +40°C)	Xenon wedge base T3-1/4	Other colors available at a premium. Please consult your sales representative		



Thomas & Betts