



# SERIES EL, E12L

TYPE: \_\_\_\_\_  
 CATALOGUE #: \_\_\_\_\_  
 NOTES: \_\_\_\_\_



## 6 & 12 Volt Emergency Lighting Units for Class I Division 2 Areas

Listed to UL924 Standards  
*Class I, Division 2,  
 Groups A, B, C & D*



**Application** Series EL (6V) and E12L (12V) self-contained emergency lighting units are designed to meet the specific requirements of Class I Division 2 hazardous areas. Typical applications include any location where flammable materials are stored, handled, or pumped, adjacent areas where separation could break down under abnormal conditions, or virtually any public or private warehouse that stores hazardous material in drums, cartons, etc.

### Features

■ **CONSTRUCTION:** All units are housed in water and corrosion-resistant cabinets constructed from glass reinforced structural foam and are fully sealed and gasketed. External electrical components, including test switch and indicator light are explosion proof in design and exceed requirements for Class I, Division 2, Group A, B, C & D. The battery compartment is vented by a one-way breather device to permit exhaust of battery gases and relief of internal pressure without admitting external moisture or corrosives. This design is also suitable for uses in Class II, Division 2 Group F & G applications.

■ **ADVANCED ELECTRONICS:**

- The Automatic microcontroller solid state charger is current limited, temperature compensated short-circuit proof and reverse polarity protected.
- Low voltage disconnect protects batteries against excessive discharge.
- Brownout protection circuit
- Dual input voltage 120V/277Vac, 60Hz, 0.3/0.15A.

■ **INSTRUMENTATION:**

- Sealed test switch, UL listed for Class I, Division 2 Operation
- Indicator light for AC-On and fault indicator (flashes)

### Battery

Series EL and E12L units feature a 6 or 12 volt maintenance-free sealed Lead Calcium battery.

### Lamp Heads

Units are equipped with a choice of incandescent or halogen PAR36 sealed beam lamps - see lamp chart below. Lamps are housed in industrial gray thermoplastic lamp shells with matching swivel. The sealed beam design completely isolates internal components from atmosphere. Wire connections are silicone sealed.

### Options

(Add Suffix to Model No.)	Suffix
Time Delay (12 min.) .....	-TD
120 Volt Heater .....	-H1
277 Volt Heater .....	-H2
NFPA .....	-FP

### Accessories

(Order as separate item)	Model
WireGuard .....	WG3-L

### Unit Selection Chart

Volts	Unit Model No.	Battery Sealed Type	Input Watts	Capacity in Watts to 87 1/2% of Nominal Battery Voltage			
				1 1/2 Hrs.	2 Hrs.	3 Hrs.	4 Hrs.
6	2EL24	Lead Calcium	24	24	18	10	6
12	2E12L56	Lead Calcium	24	56	37	21	12

### Lamp Chart

	Lamp Wattage	DC Voltage	Lamp Type	Lamp Suffix (Add to Unit Model No.)
Use with 6-Volt 2EL24 Series	8	6	Halogen	H7551
	9	6	Incandescent	7613
Use with 12-Volt 2E12L56 Series	8	12	Halogen	H7555
	12	12	Incandescent	4044

# Specifications For Series EL, E12L

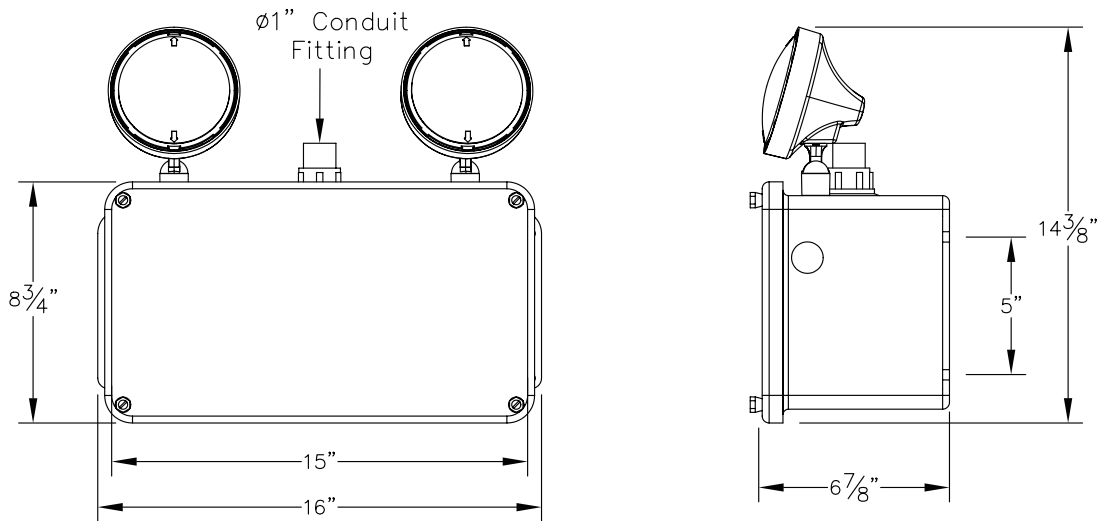

Dimensions are approximate and subject to change

**GENERAL:** The contractor shall furnish and install as indicated on all plans a 6 or 12V emergency lighting unit UL Listed for Class I, Division 2, Groups A, B, C & D hazardous areas.

**CABINET:** Shall be glass-reinforced, injection-molded structural foam. Cabinets shall be fully and mechanically gasketed around cover with all factory installed, throughwire openings to be sealed with silicone.

**LAMP HEADS:** Shall be sealed beam halogen or incandescent \_\_\_\_\_ volt \_\_\_\_\_ watts (8W halogen, 9 or 12 W incandescent). Sealed beam lamps shall be housed in an industrial thermoplastic housing with matching swivel and stainless steel screws. Wire connections to lamps shall be silicone treated.

**SURFACE TEMPERATURES:** All external elements of cabinet, swivels and lamps shall, under operating conditions, result in surface temperatures less than the ignition temperatures in Groups A, B C & D, F & G, as they are defined by NEC® Articles 500 through 503.

**EXTERNAL ELECTRICAL/MECHANICAL COMPONENTS:**

Test switch and an AC indicator light shall be designed and meet the Class I, Division 2, Groups A, B, C & D and Class II, Division 2 Groups F & G requirements. Units shall be equipped with a one-way breather vent designed for Class I, Division II, Groups A, B, C & D and Class II, Division 2 Groups F & G operation.

**SOLID STATE TRANSFER:** Activation of emergency lighting shall be by a solid state transfer device that connects load to batteries without the use of a mechanical contact.

**BATTERIES:** Series EL and E12L units shall contain sealed, maintenance-free, 6 or 12 volt lead calcium batteries.

**CHARGER:** shall be completely automatic, feature solid state components and be capable of recharging the batteries in accord with the provisions of UL 924. Charger shall provide a high charge rate immediately upon restoration of AC power and a float rate to maintain the battery at float voltages. Sealed Lead Calcium Batteries (Series EL and E12L) charger shall be an automatic solid state SCR type, controlled by a microcontroller.

**LIMITED WARRANTY:** The entire unit (less lamps and fuses) shall carry a full three (3) year warranty against defects in parts and improper workmanship under normal operation. Sealed lead calcium batteries shall carry an additional three (3) year pro-rata warranty

**MANUFACTURER:**

Unit shall be **Lightalarms** Model \_\_\_\_\_

## Ordering Information

Example: 2EL24/H7551-TD

Number of Heads	Series	Capacity Indicator	Lamp Option	Options
2 = 2 heads	EL = series	24 = capacity	/H7551 = lamp option <small>*See lamp data sheet for other lamp wattages.</small>	-TD = time delay



**Thomas & Betts**