

# ■ EC, E12C, EN, E12N Series

## 6 or 12 Volt Emergency Lighting Unit

For Operation in Hazardous Areas

Class I, Division 2, Groups C & D

Class II, Division 2, Groups E & F

Sealed Maintenance-free Lead Calcium or Nickel-Cadmium Battery

Series meets requirements for operation under

NEMA 1, 2, 3, 3R, 3S, 12 and 13 conditions

This Series of emergency lighting units are designed to meet the specific requirements of Division 2 Hazardous areas. Typical applications include any location where flammable materials are stored, handled or pumped, adjacent areas where separation could break down under abnormal conditions.

## ■ FEATURES

### Reliability

The **EC, E12C, EN and E12N Series** have a three-year full warranty (excluding lamps and fuses).

### Unit Data

All units are housed in water and corrosion resistant cabinets constructed from glass-reinforced structural foam. Cabinets fully sealed and gasketed and all external hardware is stainless steel. Door covers are hinged in such a way to permit either retention of the hinge when opened or complete removal of the door. All external electrical components, including test switch and indicator light, are explosion proof in design and exceed requirements for Division 2 areas. The battery compartment is vented by a one-way breather device to permit exhaust of battery gases and relief of internal pressure without admitting external moisture or corrosives.

### Lamp

Units are equipped with a choice of standard incandescent or halogen sealed beam lamps. Lamps are housed in gray, industrial thermoplastic shells with matching swivels. Lamp housings are rain-tight and corrosion resistant. Wire connections are silicone sealed.

### PulseType Charger

- Automatic, temperature compensated, pulse type charger.
- High capacity, automatic, dust-tight instantaneous transfer relay.
- Low voltage disconnect prevents over discharge of battery. Automatic brownout protection is provided.
- Labor saving AC line latch prevents battery discharge during installation to a non-energized circuit.
- Fused output circuit.

### Controls

- Red charger monitor LED indicates state of charge of the battery.
- Amber AC-ON LED indicates AC power is on.
- Momentary test switch allows for quick operational check of entire system.

### Power Requirements

120/277Vac 60Hz, 0.3/0.15 Amp

## ■ OPTIONS

(Add Suffix to Model No.)

Suffix

Time Delay (specify 5, 10 or 15 minutes) .....-TD\_

Shatter Resistant Lamp Coating.....-FP

## ■ ACCESSORIES

(Order as a separate item)

Model

Wire Guard .....WG3-L



## ■ DIMENSIONS

Dimensions are approximate and subject to change.

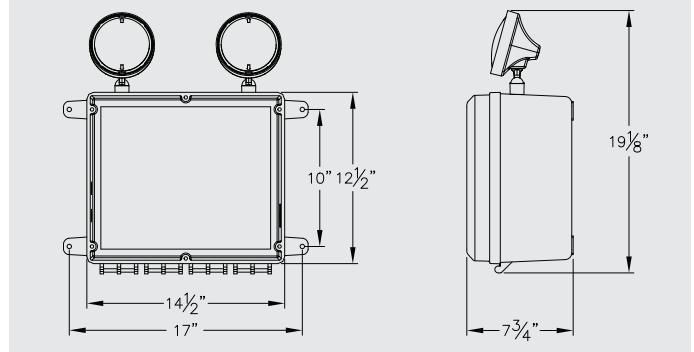

## ■ LAMP SELECTION CHART

	DC Voltage	Lamp Wattage	Lumen Output	Lamp Type	Lamp Suffix (Add to Unit Model No.)
Use With 6-Volt ECN, ENN Series	6	8	180	Halogen	H7551
		18	220	Incand.	4014
		25	350	Incand.	4510
Use with 12-Volt E12CN, E12NN Serie	12	8	180	Halogen	H7555
		18	220	Incand.	4414
		25	350	Incand.	4446

## ■ UNIT SELECTION CHART

Volts	Model No. (Unit/Lamp Suffix)	Battery Type	Input Watts	Watts to 87.5% of			
				1 1/2 hrs.	2 hrs.	3 hrs.	4 hrs.
6	2EC50	Sealed	18	50	40	30	22
	2EC100	Lead-Calcium	60	100	75	50	36
	2EN25	Sealed	40	25	20	13	9
	2EN50	NiCad	40	50	40	25	19
12	2E12C50	Sealed	18	50	40	30	22
	2E12C100	Lead-Calcium	60	100	75	50	36
	2E12N50	Sealed NiCad	60	50	40	28	20

\*National Electrical Code Specification

## ■ ORDERING FORMAT

2	EC	100	/H7551	-TD
No. of Heads	Series	Capacity Indicator	Lamp Suffix 6V 8W Incandescent	Option Time Delay