

■ ECN, E12CN, ENN, E12NN Series

6 or 12 Volt NEMA Industrial Emergency Unit
Sealed Maintenance-free Lead Calcium or
Nickel-Cadmium Battery

Series meets requirements for operation under
NEMA 1, 2, 3, 3R, 3S, 4, 4X, 12 and 13 conditions

This NEMA Industrial emergency lighting unit series are designed for use in hostile environments where the presence of water, fibers, dirt, dust and corrosive gases can be potentially damaging to internal components

■ FEATURES

Reliability

The ECN, ENN (6 volt), E12CN and E12NN (12 volt) Series have a three-year full warranty (excluding lamps and fuses).

Unit Data

All units are housed in water and corrosion resistant cabinets constructed from glass-reinforced structural foam. Cabinets are silicone sealed and/or gasketed around all entryways, push-to-test switch is completely enclosed and corrosion resistant bushing is provided for field installed conduit entry. Breather devices allow for ventilation of battery gases without admitting damaging elements. All external hardware is stainless steel. A unique door-hinging device allows for removal of door panel or retention of the hinge by means of a small field adjustment.

Lamp

Units are equipped with a choice of standard incandescent or halogen sealed beam lamps. Lamps are housed in gray, industrial thermoplastic shells with matching swivels. Lamp housings are rain-tight and corrosion resistant. Wire connections are silicone sealed.

Pulse Type Charger

- Automatic, temperature compensated, pulse type charger.
- High capacity, automatic, dust-tight instantaneous transfer relay.
- Low voltage disconnect prevents over discharge of battery. Automatic brownout protection is provided.
- Labor saving AC line latch prevents battery discharge during installation to a non-energized circuit.
- Fused output circuit.

Controls

- Red charger monitor LED indicates state of charge of the battery.
- Amber AC-ON LED indicates AC power is on.
- Momentary test switch allows for quick operational check of entire system.

Power Requirements

120/277Vac 60Hz, 0.3/0.15 Amp

■ OPTIONS

(Add Suffix to Model No.)	Suffix
Time Delay (specify 5, 10 or 15 minutes)	-TD_
Voltmeter	-V
Ammeter	-A
Lamp Disconnect Switch	-DS
Thermal Jacket (120V Heater)	-H1
Thermal Jacket (277V Heater)	-H2
Cord & Plug Kit (120V)	WP-3CP*
Cord & Plug Kit (277V)	WP-3CP-277*

*Standard cord is 3 ft. custom lengths available.

■ ACCESSORIES

(Order as a separate item)

Wire Guard	WG3-L
------------------	-------



■ DIMENSIONS

Dimensions are approximate and subject to change.

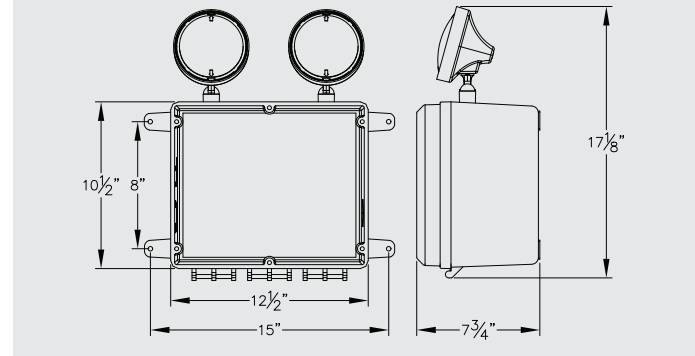

■ UNIT SELECTION CHART

Battery Type	Volts	Model No. (Unit/Lamp Suffix)	Input Watts	Watts to 87.5% of rated battery voltage*			
				1 1/2 hrs.	2 hrs.	3 hrs.	4 hrs.
Sealed Lead-Calcium	6	2ECN25	18	25	20	15	12
		2ECN50	18	50	40	30	22
		2ECN100	40	100	75	50	36
Sealed Nickel-Cadmium	6	2ENN25	18	25	20	15	12
		2ENN50	18	50	40	28	22
Sealed Lead-Calcium	12	2E12CN50	18	50	40	30	22
Sealed Nickel-Calcium		2E12NN50	18	50	40	28	22

*National Electrical Code Specification

■ LAMP SELECTION CHART

	DC Voltage	Lamp Wattage	Lumen Output	Lamp Type	Lamp Suffix (Add to Unit Model No.)
Use With 6-Volt ECN, ENN Series	6	8	180	Halogen	H7551
		18	220	Incand.	4014
		25	350	Incand.	4510
Use with 12-Volt E12CN, E12NN Serie	12	8	180	Halogen	H7555
		18	220	Incand.	4414
		25	350	Incand.	4446

■ ORDERING FORMAT

No. of Heads	Series	Capacity Indicator	Lamp Suffix	Option
2	ECN	100	/H7551	-V
			6V 8W Halogen	Voltmeter