

FG, FG12 Series – Emergency Lighting Unit

IMPORTANT SAFEGUARDS

When using electrical equipment, basic safety precautions should always be followed including the following:

READ AND FOLLOW ALL SAFETY INSTRUCTIONS

1. Do not let power supply cords touch hot surfaces.
2. Do not mount near gas or electric heaters.
3. Use caution when handling batteries. Avoid possible shorting.
4. Equipment should be mounted in locations and at heights where it will not readily be subjected to tampering by unauthorized personnel.
5. The use of accessory equipment not recommended by the manufacturer may cause an unsafe condition.
6. Caution: If optional Halogen cycle lamp(s), symbol (H—), are used in this equipment, to avoid shattering: do not operate lamp in excess of rated voltage, protect lamp against abrasion and scratches and against liquids when lamp is operating, dispose of lamp with care.
7. Halogen cycle lamps operate at high temperatures. Do not store or place flammable materials near lamp.
8. Do not use this equipment for other than intended use.
9. All servicing should be performed by qualified service personnel.

SAVE THESE INSTRUCTIONS

Installation Instructions

1. Turn off AC power.
2. Route AC circuit wires from electrical box and leave 12" of wire length.
Note — A weather tight fitting for cord connection is supplied, however, if conduit entry is desired, weather tight conduit fittings such as RACO 3400 Series or other UL recognized equivalent must be used.
Caution — Be sure to drill hole for conduit fitting in marked location below vent or where it will not interfere with circuit board or battery.
3. Remove four screws on door. Open door and lift door from hinges.
4. For units above 54W: Remove batteries for ease of installation.
5. Remove the two screws securing the battery bracket and retain.
6. Remove the battery bracket and retain.
7. Remove the battery assembly.
8. Disconnect two lamp connectors. For units with AD option, disconnect the ribbon cable from display board in door.

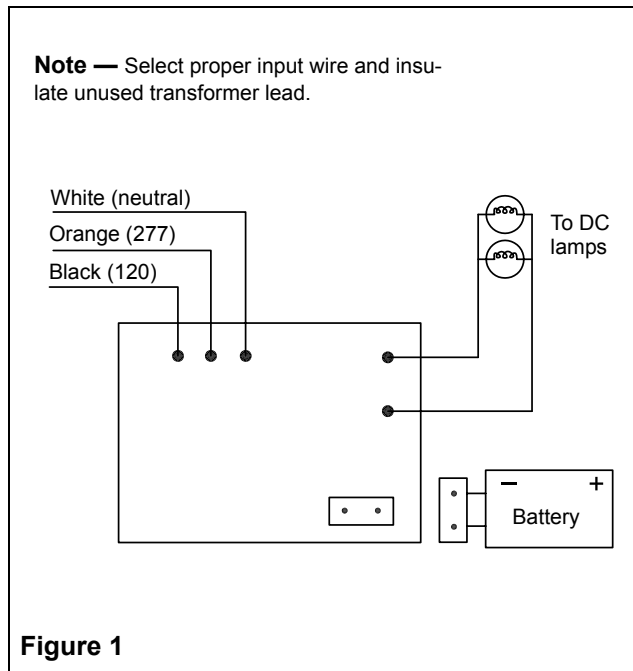

9. Securely mount unit in place. Connect AC supply wiring to unit as follows:
120 VAC — Black to 120 VAC, white to neutral.
277 VAC — Orange to 277 VAC, white to neutral.
Be sure to insulate unused wire.
10. Route supply wires through the white nylon “P” clip adjacent to the circuit board to avoid possible contact with the hot components.
11. Extend DC wiring for remote fixtures to unit, (if required), using a weather tight fitting. Wiring must comply with NEC articles 700 and 720. Do not exceed rated wattage of unit.
12. For units above 54W: Install the battery assembly. Secure battery assembly with bracket and two screws.
13. Re-connect two lamp connectors. For units with AD option, connect the ribbon cable to display board.
Note — Make sure you insert the ribbon connector properly. The connector should go in easily, if not, try reversing the connector.
14. Re-install door on hinges (do not screw to housing).
15. Connect battery to circuit board using polarized connector. Lamps will not light at this time.
16. Secure door with four screws.
17. Energize AC. Pilot lamp and high charge LED will illuminate. Allow unit to charge for 24 hours before initial full duration testing.

Testing

For units with AD option, see separate booklet.

To test: depress test switch, pilot lamp will extinguish, DC lamps will illuminate. Release switch and DC lamps will extinguish.

Maintenance

None required, however, equipment should be tested in accordance with local codes and Life Safety Code, NFPA 101. This equipment is furnished with a low battery disconnect circuit in the emergency mode. However, if the AC supply to the unit is to be disconnected for 2 months or more, the battery must be disconnected. Do not allow battery wires to short circuit.