

■ SN Series



6 Volt Emergency Unit with Remote Capability Long Life Wet Refillable Nickel-Cadmium Battery UL Listed

The **SN Series** battery unit was designed for industrial locations requiring long lasting emergency light units. Unit is available in a wide range of capacities, and offers the special advantages of the Nickel-Cadmium battery, including excellent recharging capabilities.

▣ FEATURES

Reliability

The **SN Series** has a three-year full warranty (excluding lamps and fuses).

Unit Data

The battery and all components are housed in a heavy-duty steel cabinet, with a removable front panel for ease of installation and servicing. The front panel includes a view port for visual inspection of the battery. The 6-volt, five cell pocket-plate Nickel-Cadmium battery is housed in translucent plastic cell containers. The standard cabinet finish will be gray enamel, but "mist-white" is also available (see options). All cabinets come standard with 7/8" conduit knockouts, rear keyhole mounting slots and provisions for mounting up to 3 heads on the cabinet. Mounting brackets and platforms are also available, see accessories.

Lamp

Standard with two ELF645 PAR36 high impact mar-resistant thermoplastic heads. Furnished with two 6 volt 25 watt high intensity incandescent lamps*. Other lighting head styles are also available see options. Do not exceed unit battery capacity.

For optional lamps types and wattages refer to the lamp data chart on page 108-109

PulseType Charger

- Automatic, temperature compensated, pulse type charger.
- High capacity, automatic, dust-tight instantaneous transfer relay.
- Low voltage disconnect prevents overdischarge of battery. Automatic brownout protection is provided.
- Labor saving AC line latch prevents battery discharge during installation to a non-energized circuit.
- Fused output circuit.

Controls

- Red charger monitor LED indicates state of charge of the battery.
- Amber AC-ON LED indicates AC power is on.
- Momentary test switch allow for quick operational check of entire systems.

Power Requirements

120/277Vac, 60Hz, 0.3/0.15 Amp

▣ DIMENSIONS

Dimensions are approximate and subject to change.

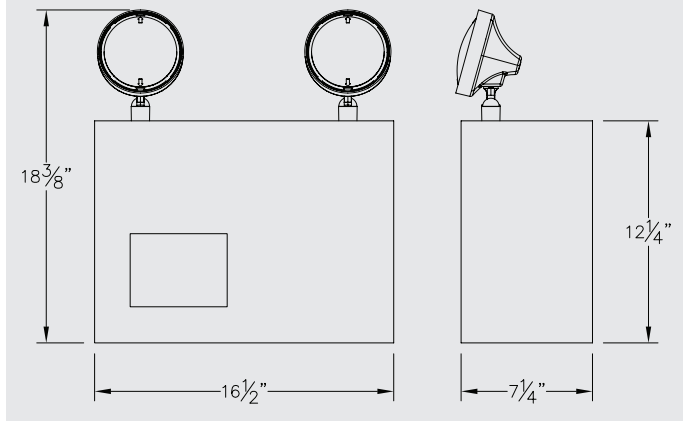

▣ UNIT SELECTION CHART

Volts	Model No. (Unit/Lamp Suffix)	Watts to 87.5% of rated battery voltage*			
		1 1/2 hrs.	2 hrs.	3 hrs.	4 hrs.
6	2SN2/L25-G	50	45	25	18
	2SN3/L25-G	70	60	35	25
	2SN4/L25-G	100	80	50	35
	2SN6/L25-G	130	105	70	50
	2SN7/L25-G	160	130	80	60

*National Electrical Code Specification

▣ ORDERING FORMAT

2	SN	4	/L25	-G	-V
No. of Heads	Series	Capacity Indicator	Lamp Suffix	Finish	Option
			6V 25W Incandescent	Gray Enamel	Voltmeter

▣ OPTIONS

(Add Suffix to Model No.)	Suffix
Mist White Color (Replace "-G" with "-M")	-M
Voltmeter	-V
Ammeter	-A
Lamp Disconnect Switch	-DS
Time Delay (specify 5, 10 or 15 minutes)	-TD_
3-Wire Cord & Plug	-3CP*
3-Wire Cord & Plug (277V)	-3CP-277*

*Standard cord is 3 ft. custom lengths available.

▣ ACCESSORIES

(Order as a separate item) Suffix