



SERIES TBR

TYPE: _____
 CATALOGUE #: _____
 NOTES: _____



Decorative Style Equipment— 6 or 12 Volt T-Bar Unit with Maintenance-Free Lead Calcium or Nickel-Cadmium Battery

Application For areas where a fully recessed “slim-line” ceiling unit is desired. Ideal for locations where there is limited wall space and where the greater directional flexibility of ceiling mounted heads is needed to provide a broader light distribution.

Features

- **CONSTRUCTION:** 20 gauge fire-resistant steel, finished in white enamel.
- **MOUNTING:** Lay-in installation in T-bar grid ceiling only and secure with tie wires. Back box has a removable cover for ease of installation and access to battery and charger.
- **ELECTRONICS:**
 - Automatic, temperature compensated, pulse type charger.
 - High capacity, automatic, dust-tight instantaneous transfer relay.
 - Low voltage disconnect prevents overdischarge of battery. Automatic brown out protection is provided.
 - Labor saving AC line latch prevents battery discharge during installation to a non-energized circuit.
 - Fused output circuit.
 - Self-testing in accordance with NFPA 101, Life Safety Code. Unit tests itself every thirty days for one minute, thirty minutes on the sixth month and ninety minutes annually.
- **CONTROLS:**
 - Charger monitor LED indicates state of charge of the battery.
 - AC-ON LED indicates AC power is on
 - Momentary test switch allows for quick operational check of entire system.
- **POWER REQUIREMENTS:**
120/277 Volt AC.

Battery

6 or 12V long life, maintenance-free sealed Lead Calcium. Nickel-Cadmium battery available (see options).

Lamp Heads

PAR 36 size, high impact mar-resistant white thermoplastic heads, furnished with high intensity incandescent lamps. **Note:** Tungsten halogen lamps optional.

Accessories

(Order as Separate Item) **Model**
 Remote Test Switch **PSW**

Options

(Add Suffix to Model No.) **Suffix**
 Black Housing and Heads **-B**
 Ammeter or Voltmeter
 (choose only one) **-A or -V***
 Improved Diagnostics **-ID**
 Improved Diagnostics (non-audible).. **-IDNA**
 Time Delay (12 min.) **-TD****
 Nickel-Cadmium Battery **-N**
 DR1130 **-DR130**
 PAR18 size heads **-ELF2**

* Not available with Diagnostics.
 ** Not required with the ID/IDNA option
Note: Certain option combinations may affect the listing. Please contact the factory for specifics.

Unit Selection Chart

Volts	Model No. (unit/ Lamp Suffix)	*Watts to 87 1/2 % of Rated Battery Voltage				Watts/ Head	Cabinet Size
		1 1/2 hrs	2 hrs	3 hrs	4 hrs		
6	2TBRC1/L9	27	20	14	10	9	S
	2TBRC2/L9	54	36	25	18	9	S
	2TBRC3/L9	81	48	33	24	9	L
12	2T12BRC2/L9	54	36	25	18	9	S

Specifications For Series TBR

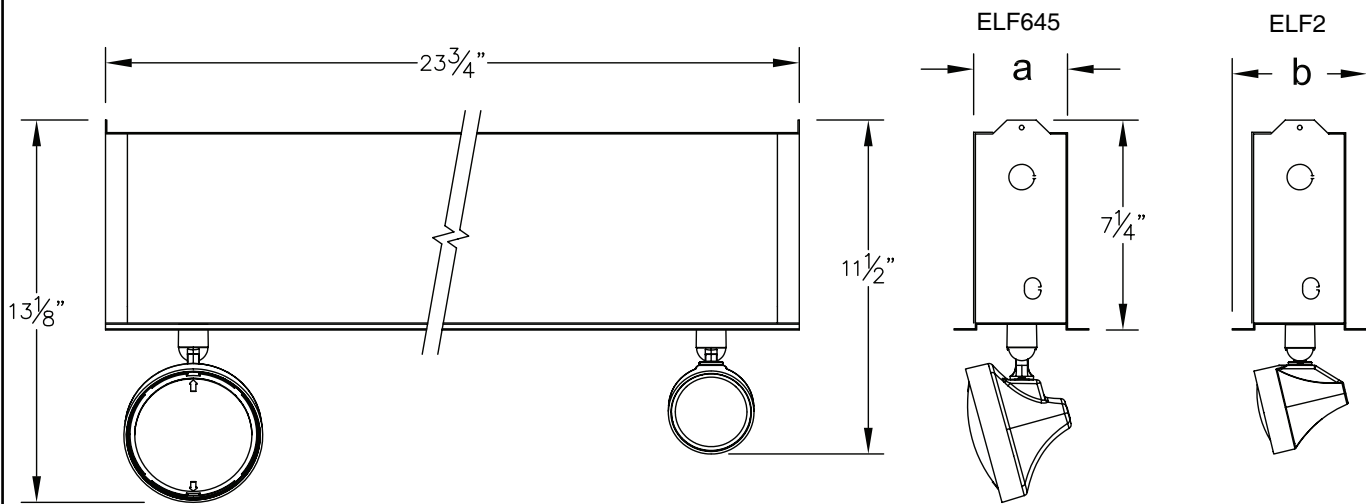

Cabinet	a	b
S	3-1/4"	4-5/8"
L	5-5/8"	7-1/8"

GENERAL: The contractor shall furnish and install 6, 12 or 24 volt emergency lighting units as indicated on all plans. Unit shall be designed for lay-in installation into the grid of a T-bar type ceiling. Unit shall be provided with two screws for attaching tie-wire. Input power shall be 120/277Vac, 60 Hz.

HOUSING: 20 gauge steel, finished in white enamel.

LAMP HEADS: One, two or three standard PAR36 size lamp assemblies shall be provided, constructed of high impact thermoplastic material, with access to lamp for replacement, and finished in a color to match the unit. Optional lamp heads available.

BATTERY: Unit shall contain 6 or 12 volt sealed, non-refillable, maintenance-free Lead Calcium or Nickel-Cadmium batteries.

TRANSFER: The sealed dust-tight transfer relay shall automatically and instantaneously connect the DC lamp load to the battery upon failure of the normal AC supply, and shall disconnect the DC lamps when normal power is restored.

CHARGER ASSEMBLY: An automatic, temperature compensated, pulse type charger shall be provided. The charger shall be reverse polarity protected, short-circuit proof and capable of recharging the battery in accordance with UL924 standard.

A low voltage disconnect shall be provided to shut off the lamp load and circuitry when battery reaches 87 1/2% discharge to protect battery from possible damage due to deep discharge. **Brownout circuit** shall be provided which activates emergency mode when AC power dips below 80-85% of nominal voltage. **AC line latch** circuit shall be provided which prevents battery discharge during installation to a non-energized circuit.

CONTROLS: AC-ON LED shall be provided to indicate the presence of AC power to the unit. **Charger monitor LED** shall be provided to indicate state of charge of the battery. Momentary test switch shall be provided to allow for periodic testing of the entire system.

WARRANTY: Entire unit (less lamps & fuses) shall carry a 3 year full warranty against defects in parts or workmanship under normal and proper use. The sealed Nickel-Cadmium battery will carry a 5 year full warranty with an additional 5 year pro-rata warranty.

MANUFACTURER:

Unit shall be Lightalarms Model _____

Ordering Information

Example: 2TBRc1L9-V

No. of Heads	Series	Battery Type	Capacity Indicator	Lamp Suffix	Options
2= 2 heads	TBR= series	C=	1=	/L9= see lamp chart	-V= voltmeter



Thomas & Betts