

Phantom™ Series

The unseen solution

12V up to 100w capacities – generator capable



Housing

- Galvanized steel back-box
- Easy access to internal components
- Head assembly door and trim plate powder coated in a white finish
- Finish can be customized on site with paint or wallpaper
- Choice of various 12 volt MR16 LED lamp wattages
- Complete 360° head assembly door rotation
- Slip gear mechanism protects unit and objects against forcible stops

Mounting

- Recessed mount into ceiling or wall with cavities
- Hanger bars included for lay-in installation in T-bar grid
- Can be installed on the wall stud or ceiling beam with simple, U-shape bracket
- Head assembly includes keyhole slot and quick-connect plugs for easy installation

Electronics

- Pulse plus charger
- Low voltage disconnect
- Automatic brownout protection
- Battery lock-out
- Fused output circuit
- Optional: Improved Diagnostics
- 120/277 60Hz

Choice of Sealed Maintenance-Free Battery

- 12V Lead-Calcium battery
- 12V Nickel-Cadmium battery

Approval

- CSA-US (To UL 924 standards)
- New York City Approved

Warranty (subject to proper installation and maintenance)

Unit: five-year limited warranty

Detailed warranty terms located on **page 182** or online at: www.lightalarms.com

Photometric performance

Lamp	Spacing center-to-center (feet)	
	7 feet mounting height	15 feet mounting height
LD7	49'	39'
LD9	68'	54'
LD10	89'	80'
50H	160'	171'

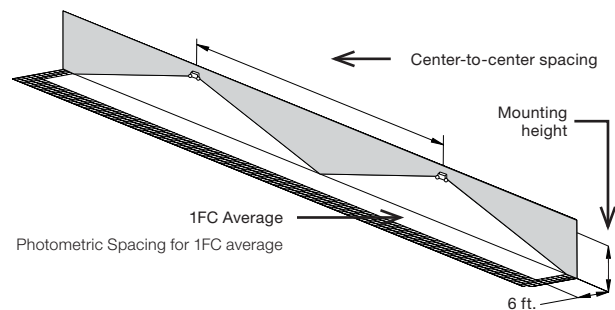

Dimensions (Dimensions are approximate and subject to change):

Charger and battery compartment:
For use in walls or ceilings with a cavity, not for use in block walls or solid ceilings.

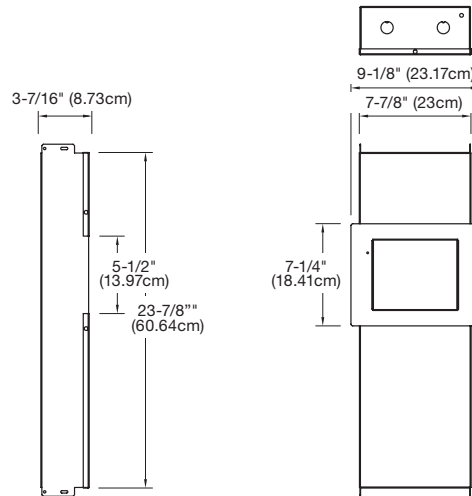

Power consumption chart

Series	Battery	Voltage	DC Specs				AC Specs					
			Battery capacity (in watts)				Units dual voltage ¹	Current			Power	
			90 Mins	2 Hrs	3 Hrs	4 Hrs		Maximum	Stand by	Maximum	Stand by	
PHM40	Lead-Calcium	12V	40	30	24	12						
PHM70	Lead-Calcium	12V	70	50	40	24						
PHM100	Lead-Calcium	12V	100	70	50	40	120VAC	0.25A	0.10A	30W	11W	
PHN40	Nickel-Cadmium	12V	40	30	24	12	277VAC	0.12A	0.05A	30W	11W	
PHN70	Nickel-Cadmium	12V	70	50	40	24						
PHN100	Nickel-Cadmium	12V	100	70	50	40						

¹ Stand-by power consumption is 50% lower for Lead-Calcium Batteries

Accessories (Order as a separate item)

Description	Product code
Remote Test Switch (Metal Faceplate)	PSW
Remote Test Switch (Plastic Faceplate)	PSW-1

Ordering format

Series	Battery	Capacity	Number of heads	Lamp type	Options
PH= Battery unit	M= Lead-Calcium N= Nickel-Cadmium	40= 12V-40W 70= 12V-70W 100= 12V-100W	-2= Two lamps	MR16 LED (LD7)= 12V-4W (LD9)= 12V-5W (LD10)= 12V-6W	MR16 Halogen High Output (50H)= 12V-50W Blank= No Options ID= Improved Diagnostics (audible) ¹ IDNA= Improved Diagnostics (non audible) ¹ T3= Time delay (15 minute) DL= Damp location ² X= Back box shipped separate

Example: PHM100-2LD7

¹ -ID & -IDNA include a time delay feature that can be enabled/ disabled in the field or set by the factory by including -ID-TD* or -IDNA-TD*

² -DL option not available with PHN100 unit

Note: For complete 12V MR16 lamp information refer to page 114 Remote Fixture, Phantom™ Series, Lamp Selection Chart

Series	Input voltage	Number of heads	Lamp type	Options
PHG= Generator unit	1= 120VAC, 60Hz 2= 277VAC, 60Hz	-2= Two lamps	MR16 LED (LD7)= 12V-4W (LD9)= 12V-5W (LD10)= 12V-6W	DL= Damp location X= Back box shipped separately

Example: PHG1-2LD7

Note: For complete 12V MR16 lamp information refer to page 114 Remote Fixture, Phantom™ Series, Lamp Selection Chart