



**CITY OF CHICAGO-APPROVED**

Life Safety Equipment



*Lightalarms*

# TABLE OF CONTENTS

**Introduction** .....Page 2, 3

## **Exit Signs**

CH Series—Cold Cathode .....4, 5  
CH XE Series, Steel Exit.....6, 7

## **Emergency Lighting**

RD CH Series .....8, 9  
TBR CH Series.....10, 11  
MG CH Series .....12, 13  
PG CH Series .....14, 15  
PQ CH Series .....16, 17  
PN CH, P12N CH Series .....18  
SN CH Series .....19

## **Unit Heads / Matching Remote Heads**

DR1130-CH Series .....20  
ELF622-CH Series .....21

**Lamp Data** .....22

**Popular Options** .....23

**Accessories** .....24, 25

**Improved Diagnostics**.....26

**Wire Size Guide** .....27

**Life Safety** .....28-30

**Terms and Conditions** .....31

**Limited Warranty** .....32



## CITY OF CHICAGO — APPROVED

Lightalarms is proud to present its complete range of Chicago-approved life safety equipment. A leading manufacturer of emergency lighting and exit signage, Lightalarms has been supplying innovative, reliable emergency lighting in the U.S. since 1953 and is pleased to continue this tradition with our newly-expanded Chicago product offering.

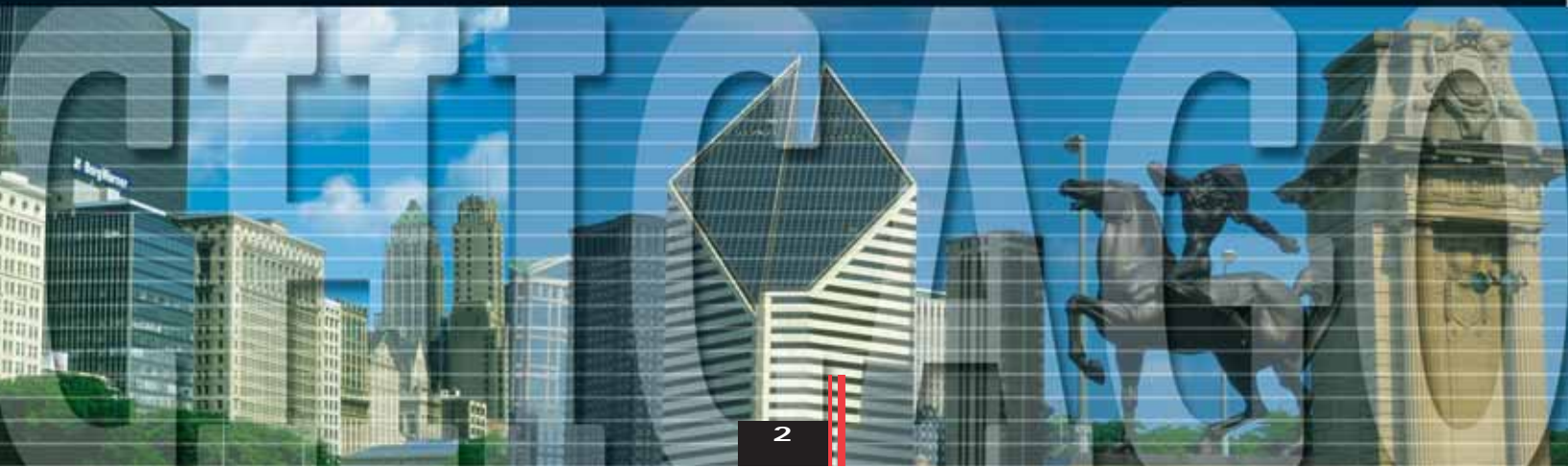

## SETTING THE STANDARD

When it comes to life safety, there can be no compromise. The Lightalarms products on the following pages are designed, manufactured and tested to meet some of the most demanding standards in North America—Chicago standards.

The complete line of Lightalarms life safety products meets or exceeds the requirements of UL 924, NFPA 101, Life Safety Code, NEC and ICC standards.

In addition, you will now find UL approved, recessed equipment, for use in “City of Chicago Environmental Airspaces” (CCEA). This mark is recognized by the Chicago Department of Buildings, Electrical Division.

From high-end architectural to industrial installations, for new construction and retrofit projects, there’s a Lightalarms product to meet your specifications.

**Lightalarms — lighting the way to safety since 1953.**

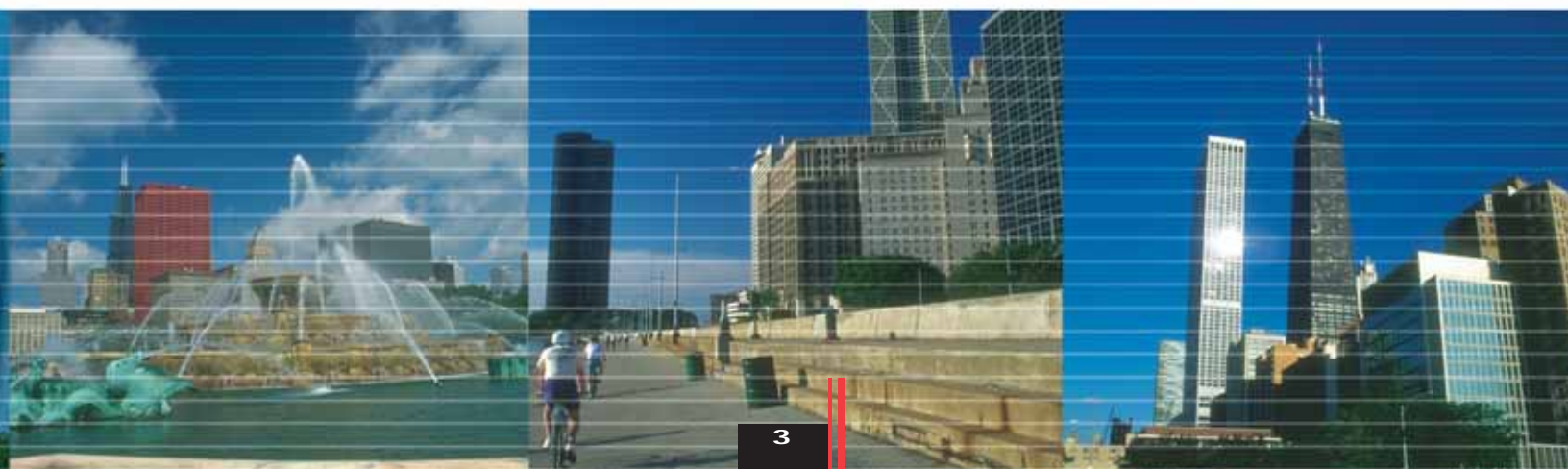

**NEW!**

# CH Series Cold Cathode

Die-Cast Aluminum, Cold-Cathode Edge-Lit,  
AC-Only or Self-Powered

Thin, sleek and efficient, the CH Series exit sign is a snap to install and complements any decor. Using high performance cold-cathode technology, the CH Series features state-of-the-art acrylic panels and precision etched lettering for maximum clarity, visibility and aesthetic appeal.

## FEATURES

- **RELIABILITY:** The CH Series has a 3-year full warranty (excluding lamps). Cold-cathode fluorescent lamps have a 3-year life expectancy.
- **POWER REQUIREMENTS:** 120/277 VAC, 60Hz, 10-watts for single or double face signs.
- **HOUSING:** Die-cast aluminum housing, trim ring, trim plate and canopy. Standard brushed aluminum, white or black finishes with other finishes available as an option (consult factory). The trim plate assembly is hinged to provide easy access to the lamps, electronics and battery.
- **TRIM PLATE:** Choice of dome or pyramid trim plates.
- **FACE PANEL:** Virgin acrylic face plate is 3/8", thin, silk-screened and computer-engraved to provide a flawless legend. Face plates are available with red letters on a white panel (single or double face).
- **MODULAR DESIGN:** Allows for quick installation in surface or recessed mounting without compromising aesthetics.
- **CIRCUITRY:** The two cold-cathode fluorescent lamps are driven independently by their own fused inverter/ballast circuits. This feature allows the sign to remain illuminated should a lamp or the driver circuit expire. Optional self-testing diagnostics are available on all self-powered models.

## MOUNTING CONFIGURATION

All mounting configurations use the same basic components. Inserting a trim ring allows for recessed mounting in walls or ceilings. Applying a canopy allows for surface mounting on ceilings or walls as back or end mount.

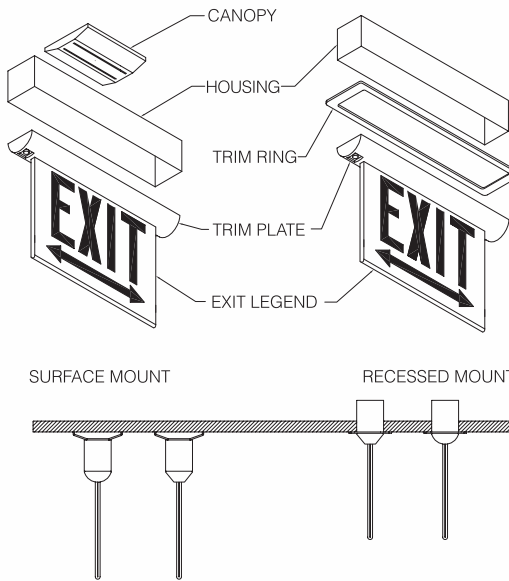

### Option

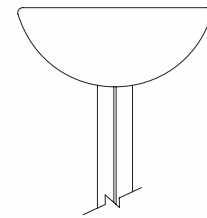

Dome Trim

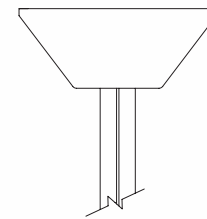

Pyramid trim

## EASY INSTALLATION

- Torsion springs on the trim plate slide into the back box to provide a tight seal between both.
- The modular design results in easy, efficient installation at the job site.

## ELECTRICAL DATA

Input AC Voltage	Frequency in Hertz	Power Consumption (in Watts)		Power Factor
		AC-Only	Self-Powered	
120	60	8.4	9.8	0.85
277	60	8.5	9.9	0.86

# CH Series Cold Cathode



## SELF-TEST/DIAGNOSTIC FEATURE (Optional)

The self-test/diagnostic feature continuously monitors the inverter charger assembly and the battery. If a fault is indicated, the external service required indicator will illuminate. The internal fault indicators will then indicate the nature of the fault. The self-test/diagnostic will self-test for 30 seconds every 30 days, 30 minutes every 60 days and 90 minutes annually. Meets NFPA 101 Life Safety Code requirements for periodic testing.

## ACCESSORIES (Order as separate item)

- Pendant, White ..... **PW** \*
- Pendant, Black ..... **PB** \*
- Replacement Lamp Assembly ..... **061903**

\*Specify length of pendant required (12", 24", 36" etc.).

## OPTIONS (Add suffix to Model No.)

- Dual Circuit ..... **-2**
- Self-Test/Diagnostic (Self-Powered Only) ..... **-D**
- Fire Alarm Activated Flasher ..... **-FAF**
- Flasher/Buzzer (Self-Powered Only) ..... **-FB**

For special wording, contact factory.  
For special finishes, contact factory.



## DIMENSIONS

### Recessed Models

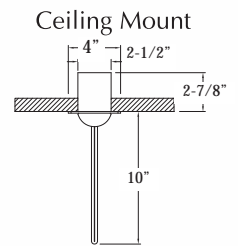
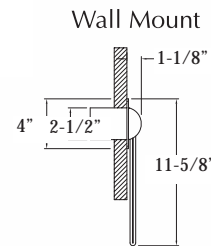

### Surface Models

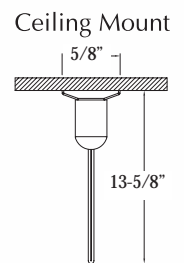
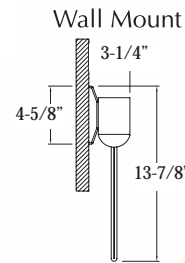

### End Mount

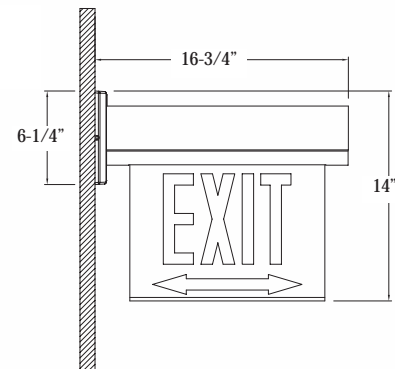

## ORDERING INFORMATION

Example: CH SED W RWD #2A

Lamp	Model	Unit Color	Panel Type	Trim	Chicago Description	Options																																								
CH = Cold Cathode Fluorescent Lamp	SED = AC-Only SPED = Self-Powered	W = White A = Brushed Aluminum B = Black	RW = Red/White	D = Dome P = Pyramid	<table border="0"> <tr> <td>Stairs, No Arrow</td> <td>#2A</td> <td>Single Face</td> <td>Double Face</td> </tr> <tr> <td>Exit, No Arrow</td> <td>#3</td> <td>#2A</td> <td>#17A</td> </tr> <tr> <td>Stairs, Arrow Right</td> <td>#5A</td> <td>#18</td> <td>#18</td> </tr> <tr> <td>Exit, Arrow Right</td> <td>#6</td> <td>-</td> <td>-</td> </tr> <tr> <td>Stairs, Arrow Left</td> <td>#8A</td> <td>-</td> <td>-</td> </tr> <tr> <td>Exit, Arrow Left</td> <td>#9</td> <td>-</td> <td>-</td> </tr> <tr> <td>Stairs, Double Arrow</td> <td>#11A</td> <td>#23A</td> <td>#23A</td> </tr> <tr> <td>Exit, Double Arrow</td> <td>#12</td> <td>#24</td> <td>#24</td> </tr> <tr> <td>Stairs, Arrow Right and Left</td> <td>#20A</td> <td>#20A</td> <td>#20A</td> </tr> <tr> <td>Exit, Arrow Right and Left</td> <td>....</td> <td>#21</td> <td>#21</td> </tr> </table>	Stairs, No Arrow	#2A	Single Face	Double Face	Exit, No Arrow	#3	#2A	#17A	Stairs, Arrow Right	#5A	#18	#18	Exit, Arrow Right	#6	-	-	Stairs, Arrow Left	#8A	-	-	Exit, Arrow Left	#9	-	-	Stairs, Double Arrow	#11A	#23A	#23A	Exit, Double Arrow	#12	#24	#24	Stairs, Arrow Right and Left	#20A	#20A	#20A	Exit, Arrow Right and Left	....	#21	#21	See Chart.
Stairs, No Arrow	#2A	Single Face	Double Face																																											
Exit, No Arrow	#3	#2A	#17A																																											
Stairs, Arrow Right	#5A	#18	#18																																											
Exit, Arrow Right	#6	-	-																																											
Stairs, Arrow Left	#8A	-	-																																											
Exit, Arrow Left	#9	-	-																																											
Stairs, Double Arrow	#11A	#23A	#23A																																											
Exit, Double Arrow	#12	#24	#24																																											
Stairs, Arrow Right and Left	#20A	#20A	#20A																																											
Exit, Arrow Right and Left	....	#21	#21																																											

# CH XE Series

Steel Exit Sign Incandescent or Fluorescent,  
AC-Only, AC/DC and Self-Powered

The CH XE Series is a steel exit sign designed for ease of installation. A fully universal exit, it is available in AC only, AC/DC and Self-Powered models. The removable side panel provides job site flexibility in changing signs for either single or double face requirements.

## FEATURES

- **RELIABILITY:** The CH XE Series has a three-year full warranty (excluding lamps).
- **HOUSING:** Rugged 20 gauge steel housing with knockouts for universal mounting to any wall or ceiling box. Available housing colors are off-white and black with a screened glass panel of red letters on a white background.
- **LIGHT SOURCE:** Incandescent signs are supplied with two long life 20WT6 d intermediate screw base incandescent lamps, uniquely angled to eliminate shadows on the face and provide uniform illumination. Also available with two compact fluorescent 7 watt lamps.
- **POWER REQUIREMENTS:** 120/277-Volts AC.
- **SELF-POWERED UNITS**
  - **BATTERY**  
Sealed, maintenance-free long-life lead
  - **ELECTRONICS**  
Automatic, temperature-compensated, pulse type charger. Instantaneous, dust-tight transfer relay. Dual diagnostic indicator lights. Low voltage battery disconnect. Labor saving battery lock-out feature to facilitate one-step installations.

## ELECTRICAL DATA

Input AC Voltage	Input Power
120 Vac	Max. 40W
277 Vac	Max. 40W



## ACCESSORIES

(Order as separate item)

- Pendant, White ..... PW- \*
- Pendant, Black ..... PB- \*
- Wire Guard (End or Ceiling Mount) ..... WG5
- Wire Guard (AC - AC/DC only, Wall Mount) ..... WG12
- Wire Guard (Self-Powered, Wall Mount) ..... WG2

\*Specify length of pendant required (12", 24" 36" etc.).

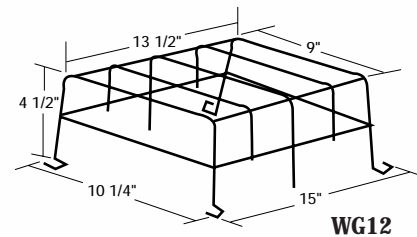
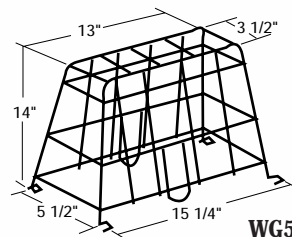
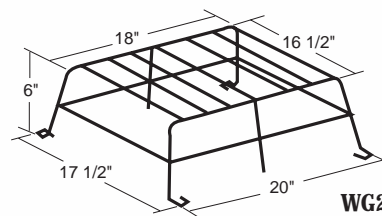

# CH XE Series



## DIMENSIONS

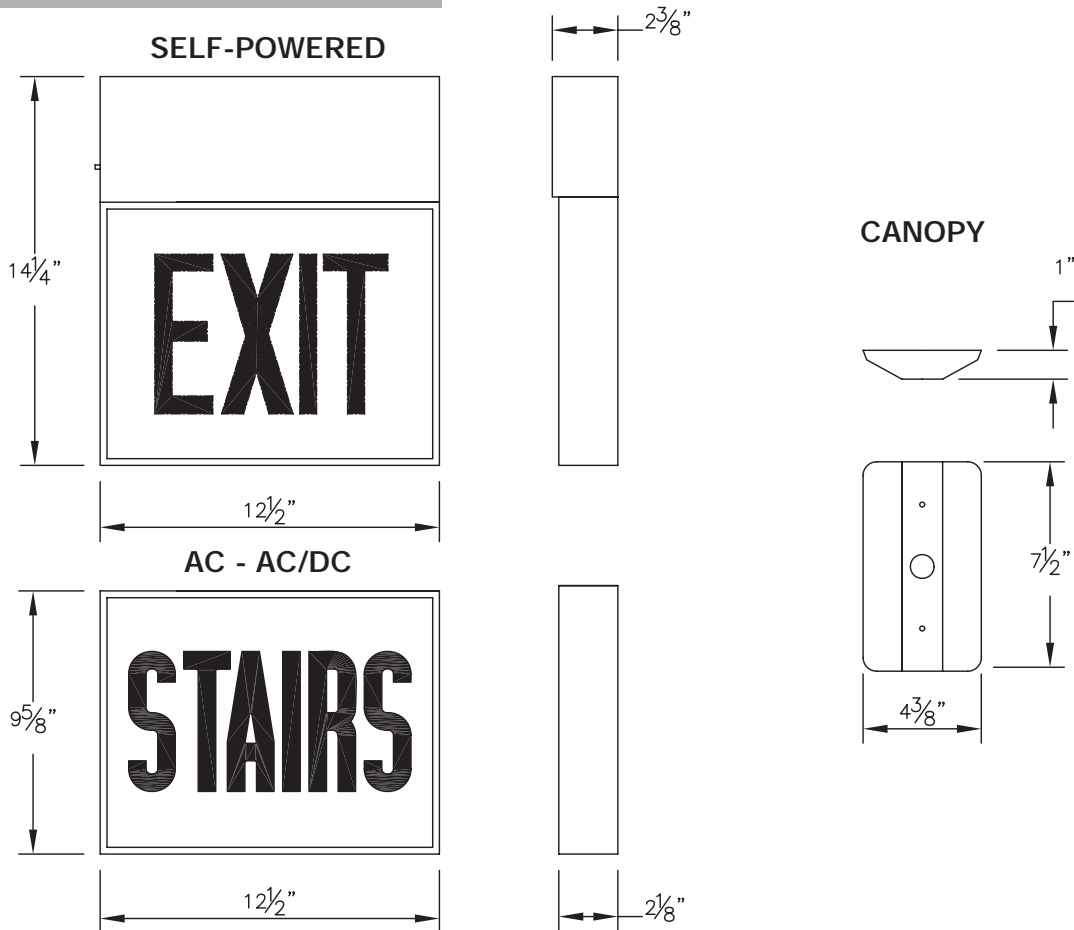

## ORDERING INFORMATION

Example: WCHXRW#2APL

DC Lamp Option	Housing Color	Series AC or AC/DC	Letter/Face Color	Chicago Description	Lamp Type	AC Input																						
Blank = AC Only 6 = 6VDC 12 = 12VDC	W = White B = Black	CHX = AC Only CHXE = Self Powered	RW = Red letters/ White Face	<table border="0"> <tr> <th>Single Face</th> <th>Double Face</th> </tr> <tr> <td>Stairs, No Arrow .....#2A</td> <td>#17A</td> </tr> <tr> <td>Exit, No Arrow .....#3</td> <td>#18</td> </tr> <tr> <td>Stairs, Arrow Right .....#5A</td> <td>-</td> </tr> <tr> <td>Exit, Arrow Right .....#6</td> <td>-</td> </tr> <tr> <td>Stairs, Arrow Left .....#8A</td> <td>-</td> </tr> <tr> <td>Exit, Arrow Left .....#9</td> <td>-</td> </tr> <tr> <td>Stairs, Double Arrow .....#11A</td> <td>#23A</td> </tr> <tr> <td>Exit, Double Arrow .....#12</td> <td>#24</td> </tr> <tr> <td>Stairs, Arrow Right and Left...-</td> <td>#20A</td> </tr> <tr> <td>Exit, Arrow Right and Left ....-</td> <td>#21</td> </tr> </table>	Single Face	Double Face	Stairs, No Arrow .....#2A	#17A	Exit, No Arrow .....#3	#18	Stairs, Arrow Right .....#5A	-	Exit, Arrow Right .....#6	-	Stairs, Arrow Left .....#8A	-	Exit, Arrow Left .....#9	-	Stairs, Double Arrow .....#11A	#23A	Exit, Double Arrow .....#12	#24	Stairs, Arrow Right and Left...-	#20A	Exit, Arrow Right and Left ....-	#21	Blank = Incandescent PL = Fluorescent	Blank = 120 VAC 277 = 277 VAC
Single Face	Double Face																											
Stairs, No Arrow .....#2A	#17A																											
Exit, No Arrow .....#3	#18																											
Stairs, Arrow Right .....#5A	-																											
Exit, Arrow Right .....#6	-																											
Stairs, Arrow Left .....#8A	-																											
Exit, Arrow Left .....#9	-																											
Stairs, Double Arrow .....#11A	#23A																											
Exit, Double Arrow .....#12	#24																											
Stairs, Arrow Right and Left...-	#20A																											
Exit, Arrow Right and Left ....-	#21																											



**NEW!**

# RD CH Series

Decorative Style Recessed Equipment  
6 and 12-Volt, Maintenance-Free, Lead Calcium  
Long-Life Lead or Nickel Cadmium Battery

The RD CH Series combines decorative styling, rugged construction and high performance for fully recessed applications. The low profile RD CH Series is unobtrusive, blends in well with any interior, and can be recessed in ceilings or walls.

## FEATURES

- **RELIABILITY:** The RD CH Series has a three-year full warranty (excluding lamps).
- **CONSTRUCTION:** Construction of 20 gauge steel with an mist-white backed enamel finish. Unit and lamp head color is pure white when MR16 lamps are ordered.
- **MOUNTING:** Easily recesses into wall or ceiling. Mounting brackets included for installation in grid type suspended ceilings. Unit comes standard with 16" adjustable bar hangers. Furnished with ELF622 heads with 6- or 12-volt lamps as specified.
- **ELECTRONICS:**
  - Automatic, temperature-compensated, pulse-type charger.
  - High capacity, automatic, dust tight instantaneous transfer relay.
  - Low voltage disconnect prevents over discharge of battery. Automatic brown out protection is provided.
  - Labor saving AC line latch prevents battery discharge during installation to a non-energized circuit.
- **CONTROLS:**
  - Red charge monitor LED indicates state of charge of the battery.
  - Amber AC-ON LED indicates AC power is on.
  - Momentary test switch allows for quick operational check of entire system.
- **POWER REQUIREMENTS:**
  - 120/277-Volt AC.

## APPLICATIONS

Ideal for use in applications that require fully-recessed, architecturally-styled units.

## BATTERY

Unit comes standard with 6 or 12-volt maintenance-free, sealed lead calcium battery. Nickel cadmium battery available as an option.

## UNIT SELECTION CHART

Sealed Maintenance-Free Battery Types	D.C. Voltage	Model Number		*Watts to 87-1/2% of Rated Battery Voltage			
		ELF622 Lamps Heads	DR1130 Lamp Heads	1 1/2 Hrs	2 Hrs	3 Hrs	4 Hrs
Nickel Cadmium	6	2RD6C2/*-CH	—	25	18	12	9
	12	2RD12C3/*-CH	2RD12C3/1130-M12	36	21	15	12
Long-Life Lead	6	2RD6E2/*-CH	—	27	19	14	10
	6	2RD6E3/*-CH	—	36	24	17	13
	12	2RD12E3/*-CH	2RD12E3/1130-M12	36	24	17	13
Lead Calcium	6	2RD6M2/*-CH	—	27	18	14	10
	6	2RD6M3/*-CH	—	36	25	20	14
	12	2RD12M3/*-CH	2RD12M3/1130-M12	36	25	20	14

\*National Electrical Code Specification.

### UNIT LAMP SELECTION

ELF622 heads supplied with 6 or 12-volt, 12-watt lamp. Lamp type must be specified.

- 6-volt, 12-watt PAR 36 sealed beam halogen = H7553
- 12-volt, 12-watt PAR 36 sealed beam halogen = H7557
- 12-volt, 12-watt Bi-Pin halogen = LH3

DR1130 heads supplied with 12-volt, 12-watt MR16 lamp.

# RD CH Series



## LAMP HEADS

Supplied with ELF622 heads with 6 or 12-volt 12-watt, PAR36 lamp type as specified. DR1130 heads are available on 12-volt units, supplied with 12-watt MR16 lamps (see Unit Selection Chart). Unit and lamp head color is pure white when MR16 lamps are ordered.

## ORDERING FORMAT

$\frac{2}{1}$   $\frac{RD}{2}$   $\frac{12}{3}$   $\frac{C}{4}$   $\frac{3-LH3}{5}$   $\frac{-1130}{6}$   $\frac{-CH}{7}$   $\frac{-M}{8}$   $\frac{-ID}{9}$

- ① — **2**.....No. of Heads (0, 1, 2)
- ② — **RD** .....Series
- ③ — **12**.....DC Battery Backup  
(6=6 VDC, 12=12 VDC)
- ④ — **C**.....Battery Type  
(M=Lead Calcium, E=Long-Life Lead  
C=Nickel Cadmium)
- ⑤ — **3**.....Capacity Indicator  
(See Unit Selection Chart)
- ⑥ — **/LH3**.....Lamp Suffix (See Lamp Selection Chart P.22)
- ⑦ — **/1130**.....DR1130 Lighting Heads
- ⑧ — **-CH**.....City of Chicago Spec.
- ⑨ — **-M**.....Standard Mist White Finish
- ⑩ — **-ID**.....Improved Diagnostics (See Options)



## DIMENSIONS

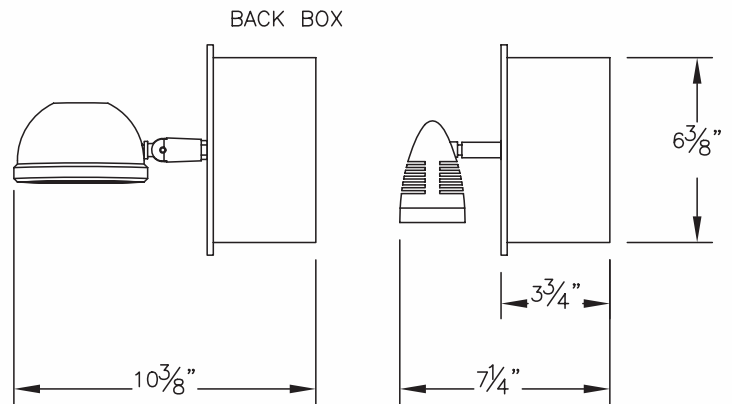
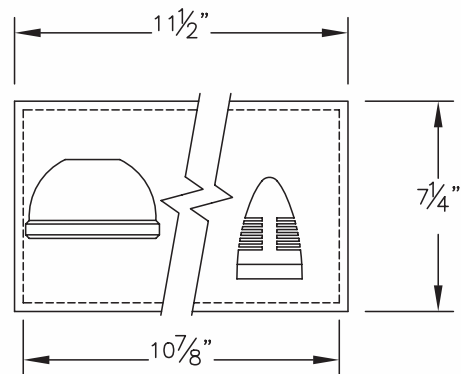

## OPTIONS

(Add suffix to Model No.)

- Black Housing and Heads (replace "M" by).....**-B**
- Ammeter or Voltmeter (choose only one) .....**-A\* or -V \***
- Improved Diagnostics .....**-ID**
- Improve Diagnostics, Non-Audible .....**-IDNA**
- Time Delay .....**-TD \*\***
- Non-Standard Input Voltage .....**Specify**

\* Not available with ID/IDNA option.  
\*\* Not required when using the ID/IDNA option.

## ACCESSORIES

(Order as separate item)

- Wire Guard ..... **WG6**  
(ELF622 or DR1130 heads)
- 27" Adjustable Bar Hangers ..... **BH-RD**
- Remote Test Switch, Metal Faceplate..... **-RTS**



# TBR CH Series

Decorative Style Recessed Equipment  
6 and 12-Volt, Maintenance-Free,  
Lead Calcium or Nickel Cadmium Batteries

The TBR CH Series combines decorative styling, rugged construction and high performance for fully recessed applications. Low profile, the TBR CH Series is unobtrusive, blends in well with any interior, and is designed to be recessed in grid ceilings.

## FEATURES

- **RELIABILITY:** The TBR CH Series has a three-year full warranty (excluding lamps).
- **CONSTRUCTION:** 18-gauge, steel, finished in mist white enamel. Provision for mounting up to three heads. Unit and lamp head color is pure white when MR16 lamps are ordered.
- **MOUNTING:** Lay-in installation in T-bar grid ceiling. Back box has removable cover for ease of installation and full access to battery and charger.
- **ELECTRONICS:**
  - Automatic, temperature compensated, pulse type charger.
  - High capacity, automatic, dust tight instantaneous transfer relay.
  - Low voltage disconnect prevents overdischarge of battery. Automatic brownout protection is provided.
  - Labor saving AC line latch prevents battery discharge during installation to a non-energized circuit.
  - Fused output circuit.
- **CONTROLS:**
  - Red charge monitor LED indicates state of charge of the battery.
  - Amber AC-ON LED indicates AC power is on.
  - Momentary test switch allows for quick operational check of entire system.
- **POWER REQUIREMENTS:**
  - 120/277-Volt AC.

## APPLICATIONS

For areas where a fully recessed "slim-line" ceiling unit is required. Ideal for locations where there is limited wall space and where the greater directional flexibility of ceiling-mounted heads is needed to provide a broader light distribution.

## BATTERY

6 or 12-volt, long life, maintenance-free, sealed lead calcium. Nickel cadmium available as an option.

## UNIT SELECTION CHART

Volts	Model No. (Unit/Lamp Suffix)	Capacity in Watts to 87-1/2% of Nominal Battery Voltage				Cabinet
		1-1/2 Hrs	2 Hrs	3 Hrs	4 Hrs	
6	2TBRC1-CH/H7553	27	20	14	10	A
	2TBRC2-CH/H7553	54	36	25	18	A
	2TBRC3-CH/H7553	81	48	33	24	B
12	2T12BRC2-CH/LH3	54	36	25	18	A

# TBR CH Series



## ORDERING FORMAT

**① 2**    **TBR**    **C1**    **-CH**    **/H7553**    **-M**    **-ID**  
 ①    ②    ③    ④    ⑤    ⑥    ⑦

- ①— **2**.....No. of Heads (0, 1, 2, 3)
- ②— **TBR**.....Series  
(TBR=6 VDC, T12BR=12 VDC)
- ③— **C1**.....Capacity Indicator  
(See Unit Selection Chart)
- ④— **-CH**.....City of Chicago Spec.
- ⑤— **/H7553** .....Lamp Suffix\*
- ⑥— **-M**.....Standard Mist White Finish
- ⑦— **-ID** .....Improved Diagnostics (See Options)

\* See lamp chart on p. 22 for alternate lamps. Do not exceed unit rating in capacity or voltage.

## LAMP HEADS

All metal, ELF622 heads are standard and supplied with 6-volt or 12-volt, PAR36 12-watt lamps as specified. DR1130 heads are optional on 12-volt units and may be 12-watt or 20-watt MR16 lamps.

Example:  
 2T12BRC2-CH/1130-M12    12-Watt MR16  
 2T12BRC2-CH/1130-M20    20-Watt MR16

Unit and lamp head color is pure white when MR16 lamps are ordered.



**CCEA**  
APPROVED



## DIMENSIONS

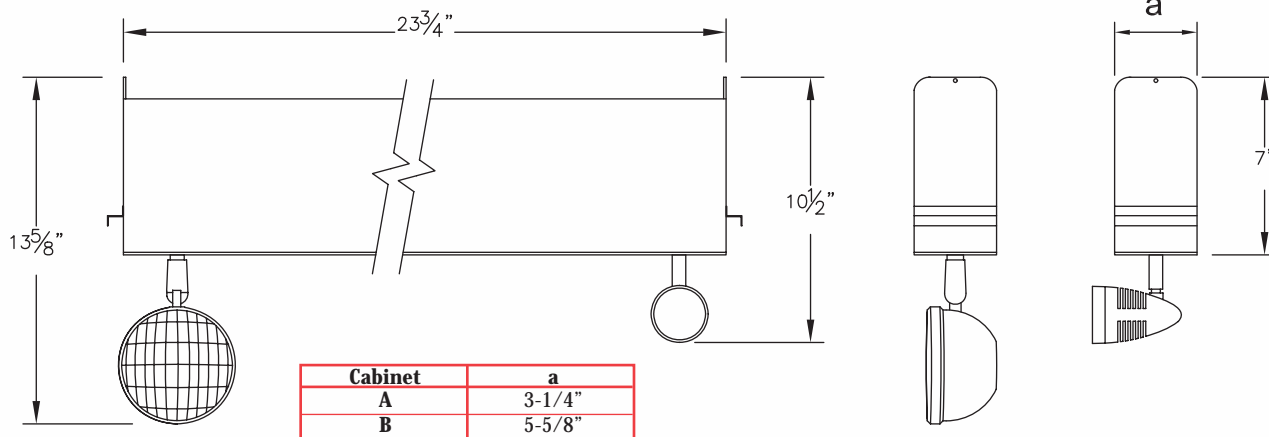

## OPTIONS

(Add suffix to Model No.)

- Black Housing and Heads (replace "M" by).....**-B**
- Voltmeter.....**-V\***
- Time Delay (12 min.) .....**TD\*\***
- Improved Diagnostics .....**-ID**
- Improved Diagnostics, Non-Audible .....**-IDNA**
- Nickel Cadmium Battery .....**-N**

\* Not available with ID/IDNA option.

\*\* Not required with ID/IDNA option.

## ACCESSORIES

(Order as separate item)

- Remote Test Switch, Metal Faceplate .....**-RTS**

# MG CH Series

Industrial/Commercial Unit Equipment,  
6 and 12- Volt, Maintenance-Free,  
Lead Calcium or Nickel Cadmium Battery

The MG CH Series is an excellent combination of economy, quality and versatility. Its compact, all-metal housing is offered in a wide variety of battery choices and wattages. The MG CH Series comes with our highly reliable pulse type charger. Improved Diagnostics are available as an option.

## APPLICATION

Compact housing design meets most requirements for moderate loads. Reliable, economic units for most commercial applications.

## UNIT SELECTION CHART

Sealed Maintenance-Free Battery Types	Volts	Model No. (Unit/Lamp Suffix)	Capacity in Watts to 87-1/2% of Nominal Battery Voltage				Cabinet Size
			1-1/2 Hrs	2 Hrs	3 Hrs	4 Hrs	
Lead Calcium	6	2MG27CH/LHK-M	27	18	14	10	S
		2MG54-CH/LHK-M*	54	37	28	21	L
	12	2M12G36-CH/LH3-M	36	25	20	14	S
		2M12G54-CH/LH3-M*	54	37	28	21	L
Nickel Cadmium	6	2MN25-CH/LHK-M	25	18	12	9	S
	12	2M12N36-CH/LH3-M	36	21	15	12	S
		2M12N50-CH/LH3-M	50	36	25	18	S

12V, 12W Bi-Pin Halogen, ELF622-CH Heads  
12V, 20W, MR16, DR1130 Heads  
12V, 12W, MR16, DR1130 Heads

\* Do not exceed unit rating in voltage or capacity.  
See lamp chart on page 22.

## FEATURES

- **RELIABILITY:** The MG CH Series comes complete with a 3-year full warranty (excluding lamps).
- **HOUSING:** Constructed of 20 gauge steel with an off-white, baked enamel finish. Hinged cabinet door for easy access. Furnished standard with two ELF622 heads with one 12-watt lamp per head (see Unit Selection Chart). Unit and lamp head color is pure white when MR16 lamps are ordered.
- **MOUNTING:** Conduit knockouts and rear keyhole mounting slots are provided.
- **ELECTRONICS:**
  - Automatic, temperature compensated, pulse type charger.
  - High capacity, automatic, dust-tight instantaneous transfer relay.
  - Low voltage disconnect prevents overdischarge of battery. Automatic brownout protection is provided.
  - Labor saving AC line latch prevents battery discharge during installation to a non-energized circuit.
- **CONTROLS:**
  - Red charge monitor LED indicates state of charge of the battery.
  - Orange AC-ON LED indicates AC power is on.
  - Momentary test switch allows for quick operational check of entire system.
- **POWER REQUIREMENTS:**
  - 120/277 Volt AC

# MG CH Series



## ORDERING FORMAT

$\frac{2}{1}$   $\frac{MG}{2}$   $\frac{27}{3}$   $\frac{-CH}{4}$   $\frac{/LHK}{5}$   $\frac{-M}{6}$   $\frac{-V}{7}$

- ①— **2**.....No. of Heads (0, 1, 2, 3)
- ②— **MG** .....Series/DC Voltage  
(MG=6 VDC, M12G=12 VDC)
- ③— **27**.....Capacity Indicator  
(See Unit Selection Chart)
- ④— **-CH**.....City of Chicago Spec.
- ⑤— **/LHK**.....Lamp Suffix\*
- ⑥— **-M**.....Standard Mist White Finish
- ⑦— **-V**.....Voltmeter (See Options)

\* See lamp chart on p. 22 for alternate lamps. Do not exceed unit rating in capacity or voltage.

## LAMP HEADS

All metal, ELF622 heads are standard and supplied with 6 or 12-volt, 12-watt lamps as specified. DR1130 heads are optional on 12-volt units and may be 12 or 20-watts.

Example:

M12G36-CH/1130-M12      12-Watt MR16

M12G36-CH/1130-M20      20-Watt MR16

Unit and lamp head color is pure white when MR16 lamps are ordered.

Note: Do not exceed unit rating in voltage or capacity.



## DIMENSIONS

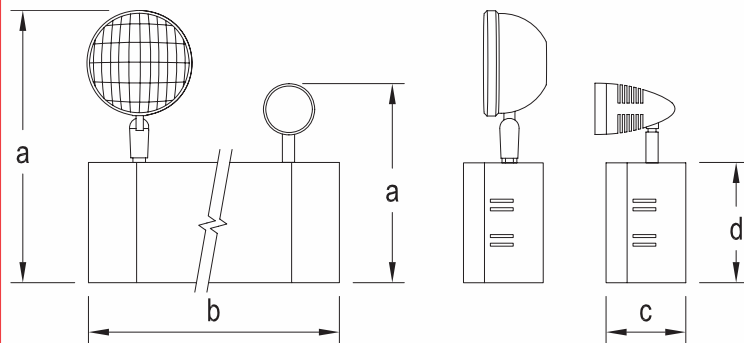

Cabinet	a	b	c	d
S	11-7/8"//8-3/4"	11"	3-1/2"	5-1/4"
L	13"//9-7/8"	12-3/4"	4"	6-3/8"

## OPTIONS

(Add suffix to Model No.)

- Black Housing and Heads .....**-B**
- Ammeter or Voltmeter (choose only one) .....**-A or -V \***
- Disconnect Switch .....**-DS**
- Improved Diagnostics .....**-ID \*\***
- Improved Diagnostics, Non-Audible .....**-IDNA**
- Time Delay (12 minutes) .....**-TD \*\*\***
- Tamper Proof .....**-TP**
- Front Mounted Heads (for low ceilings) .....**-FM**
- 3-wire Cord & Plug .....**-3CP**
- 3-wire Cord & Plug (277V) .....**-3CP-277**

\*Not available with ID/IDNA option.

\*\*Only available with Lead Calcium battery.

\*\*\*Not required when using the ID/IDNA option.

## ACCESSORIES

(Order as separate item)

- Mounting Platform .....**MP-PQA**
- Wire Guard (S Cabinet) .....**WG1**
- Wire Guard (L Cabinet) .....**WG2**
- Wire Guard (Front Mounted Heads) .....**WG10**
- Polycarbonate Vandal Resistant Shield (L Cabinet) .....**CPS**
- NEMA-4X Polycarbonate Vandal Resistant Shield (S Cabinet) .....**CPS-4X**

# PG CH Series

Industrial/Commercial Unit Equipment  
6 and 12-Volt, Maintenance-Free Lead Calcium Battery

The PG CH Series is a traditionally-styled, multi-purpose emergency lighting unit that offers reliability, versatility, performance and cost-efficiency in an aesthetically-pleasing design.

## APPLICATIONS

Designed to meet requirements for moderate loads, the PG CH, P12G CH Series is a reliable, economical choice for most public areas.

## BATTERY

6 or 12-Volt, maintenance-free sealed lead calcium. Battery capacities meet the 90 minute required run time or extended run times based on lamp load.

## UNIT SELECTION CHART

Volts	Model No. (Unit/Lamp Suffix)	Capacity in Watts to 87-1/2% of Nominal Battery Voltage			
		1-1/2 Hrs	2 Hrs	3 Hrs	4 Hrs
6	2PG1-CH/H7553-M	27	20	14	10
	2PG2-CH/H7553-M	54	36	27	18
12	2P12G1-CH/LH3-M	54	36	27	18

## FEATURES

- **RELIABILITY:** The PG CH Series has a three-year full warranty (excluding lamps).
- **HOUSING:** Heavy duty steel case with front access panel and mist white enamel finish.  
Unit and lamp head color is pure white when MR16 lamps are ordered.
- **MOUNTING:** Conduit knockouts and rear keyhole mounting slots are provided.
- **ELECTRONICS:**
  - Automatic, temperature-compensated, pulse-type charger.
  - High capacity, automatic, dust tight instantaneous transfer relay.
  - Labor-saving AC line latch prevents battery discharge during installation to a non-energized circuit.
  - Low voltage disconnect prevents over discharge of battery. Automatic brownout protection is provided.
  - Fused output circuits (PG2 CH, P12G1 CH).
- **CONTROLS:**
  - Red charger monitor LED indicates state of charge of the battery.
  - Amber AC-ON LED indicates AC power is on.
  - Momentary test switch allows for quick operational check of entire system.
- **POWER REQUIREMENTS:**
  - 120/277-Volt AC, 0.25A, 30W (max.).

# PG CH Series



## ORDERING FORMAT

**2 PG 1 -CH /H7553 -M -ID**  
 ① ② ③ ④ ⑤ ⑥ ⑦

- ①— **2**.....No. of Heads (0, 1, 2, 3)
- ②— **PG** .....Series/DC Voltage  
(PG=6 VDC, P12G=12 VDC)
- ③— **1**.....Capacity Indicator  
(See Unit Selection Chart)
- ④— **-CH**.....City of Chicago Spec.
- ⑤— **/H7553**.....Lamp Suffix\*
- ⑥— **-M**.....Standard Mist White Finish
- ⑦— **-ID**.....Improved Diagnostics (See Options)

\* See lamp chart on p. 22 for alternate lamps. Do not exceed unit rating in capacity or voltage.

## LAMP HEADS

All metal, ELF622 heads are standard and supplied with 6 or 12-volt, 12-watt lamps as specified. DR1130 heads are optional on 12-volt units and may be 12 or 20-watts.

Example:

2P12G1-CH/1130-M12 12-Watt MR16  
 2P12G1-CH/1130-M20 20-Watt MR16

Unit and lamp head color is pure white when MR16 lamps are ordered.

## DIMENSIONS

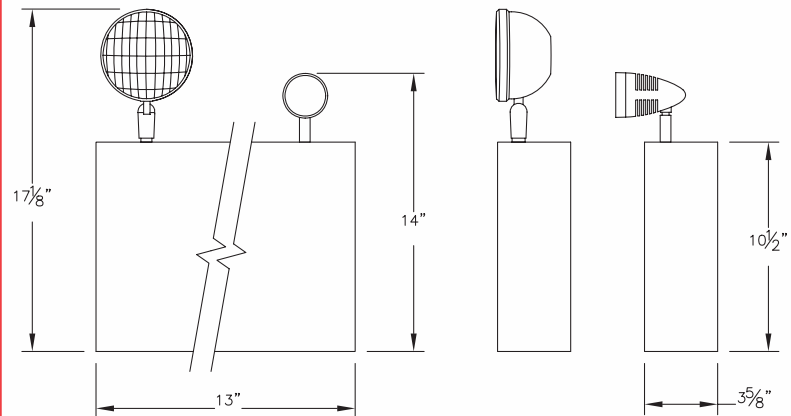

Listed

## OPTIONS

(Add suffix to Model No.)

- Black Housing and Heads ..... **-B**
- Voltmeter ..... **-V \***
- Disconnect Switch ..... **-DS**
- Improved Diagnostics ..... **-ID**
- Improved Diagnostics, Non-Audible ..... **-IDNA**
- Time Delay ..... **-TD \*\***
- Tamper Proof ..... **-TP**
- 3-Wire Cord and Plug ..... **-3CP**
- 3-Wire Cord and Plug (277V) ..... **-3CP-277**

\*Not available with ID/IDNA option.

\*\*Not required with the ID/IDNA option.

## ACCESSORIES

(Order as separate item)

- Wire Guard ..... **WG2**
- Mounting Platform ..... **MP-PQA**



# PQ CH Series

Industrial/Commercial Unit Equipment, 6 and 12-Volt,  
Maintenance-Free, Lead Calcium Battery

The PQ CH, P12Q CH Series is a traditionally styled battery unit with high capacity, maintenance-free batteries — the perfect combination of function and performance for most industrial and commercial environments.



## APPLICATIONS

Industrial, institutional and commercial environments where remote capability or extended operating times are required.

## BATTERY

6 or 12-volt, maintenance-free sealed lead calcium.

## UNIT SELECTION CHART

Volts	Model No. (Unit/Lamp Suffix)	Capacity in Watts to 87-1/2% of Nominal Battery Voltage				Cabinet
		1-1/2 Hrs	2 Hrs	3 Hrs	4 Hrs	
6	2PQ2-CH/H7553-M	100	75	50	36	B
	2PQ3-CH/H7553-M	200	150	100	72	C
12	2P12Q1-CH/LH3-M	100	75	50	36	B
	2P12Q2-CH/LH3-M	200	150	107	85	C

## FEATURES

- **RELIABILITY:** The PQ CH, P12Q CH Series has a three-year full warranty (excluding lamps).
- **HOUSING:** Heavy duty steel case with front access panel has mist white enamel finish.  
Unit and lamp head color is pure white when MR16 lamps are ordered.
- **MOUNTING:** Conduit knockouts and rear keyhole mounting slots are provided.
- **ELECTRONICS:**
  - Automatic, temperature compensated, pulse type charger.
  - High capacity, automatic, dust tight instantaneous transfer relay.
  - Low voltage disconnect prevents overdischarge of battery. Automatic brownout protection is provided.
  - Labor saving AC line latch prevents battery discharge during installation to a non-energized circuit.
  - Fused output circuit.
- **CONTROLS:**
  - Red charge monitor LED indicates state of charge of the battery.
  - Amber AC-ON LED indicates AC power is on.
  - Momentary test switch allows for quick operational check of entire system.
- **POWER REQUIREMENTS:**
  - 120/277-Volt AC.

# PQ CH Series



## ORDERING FORMAT

- $\frac{2}{1}$   $\frac{PQ}{2}$   $\frac{2}{3}$   $\frac{-CH/H7553}{4}$   $\frac{-M}{5}$   $\frac{-V}{6}$   $\frac{-V}{7}$   
 ①— **2**.....No. of Heads (0, 1, 2, 3)  
 ②— **PQ**.....Series/DC Voltage  
           (PQ = 6 VDC, P12Q = 12 VDC)  
 ③— **2**.....Capacity Indicator  
           (See Unit Selection Chart)  
 ④— **-CH**.....City of Chicago Spec.  
 ⑤— **/H7553**.....Lamp Suffix\*  
 ⑥— **-M**.....Standard Mist White Finish  
 ⑦— **-V**.....Voltmeter (See Options)

\* See lamp chart on p. 22 for alternate lamps.  
 Do not exceed unit rating in capacity or voltage.

## LAMP HEADS

All metal, ELF622 heads are standard and supplied with 6 or 12-volt, 12 watt lamps as specified. DR1130 heads are optional on 12-volt units and may be 12, 20 or 35 watts.

Example:

- 2P12Q1-CH/1130-M12   12-Watt MR16  
 2P12Q1-CH/1130-M20   20-Watt MR16  
 2P12Q1-CH/1130-M35   35-Watt MR16

Unit and lamp head color is pure white when MR16 lamps are ordered.

Note: Do not exceed unit rating in voltage or capacity.

## DIMENSIONS

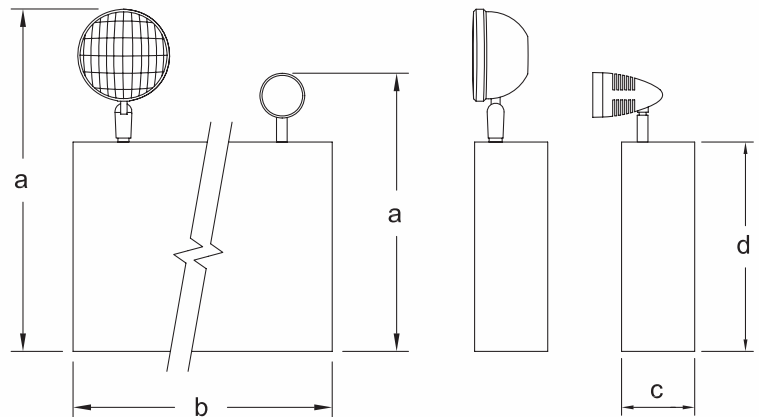

Cabinet	a	b	c	d
<b>B</b>	17-1/8"//14"	16-1/8"	5-1/2"	10-1/2"
<b>C</b>	19"//15-7/8"	16-1/2"	7-1/2"	12-1/4"



## OPTIONS

(Add suffix to Model No.)

- Black Housing and Heads..... **-B**  
 Voltmeter..... **-V \***  
 Ammeter..... **-A \***  
 Improved Diagnostics..... **-ID**  
 Improved Diagnostics, Non-Audible..... **-IDNA**  
 Time delay (12 min.)..... **-TD \*\*\***  
 Tamper Proof..... **-TP**  
 3-Wire Cord & Plug..... **-3CP**  
 3-Wire Cord & Plug (277V)..... **-3CP-277**

Available with either voltmeter or ammeter - not both.

\*Voltmeter and ammeter not available with the ID/IDNA option.

\*\*\*Not required with ID/IDNA option.

## ACCESSORIES

(Order as separate item)

- Wire Guard..... **WG3**  
 Mounting Platform..... **MP-PQB**

# PN CH, P12N CH Series

Industrial/Commercial Unit Equipment 6 or 12-Volt,  
Maintenance-Free, Nickel Cadmium Battery

The PN CH, P12N CH Series is a traditionally styled, high performance unit. Long-life nickel cadmium batteries are maintenance-free and designed specifically for environments where lighting units may be exposed to fluctuations in temperature.

## FEATURES

- **RELIABILITY:** The PN CH, P12N CH Series has a three-year full warranty (excluding lamps).
- **HOUSING:** Heavy duty steel case with front access panel and mist white enamel finish. Unit and lamp head color is pure white when MR16 lamps are ordered.
- **MOUNTING:** Conduit knockouts and rear keyhole mounting slots are provided.
- **ELECTRONICS:**
  - Automatic, temperature-compensated, pulse-type charger.
  - High capacity, automatic, dust-tight instantaneous transfer relay.
  - Labor-saving AC line latch prevents battery discharge during installation to a non-energized circuit.
  - Automatic brownout protection is provided.
  - Fused output circuit.
- **CONTROLS:**
  - Red charger monitor LED indicates state of charge of the battery.
  - Amber AC-ON LED indicates AC power is on.
  - Momentary test switch allows for quick operational check of entire system.
- **POWER REQUIREMENTS:**
  - 120/277-Volt AC.

## APPLICATIONS

Recommended where the long-life and maintenance-free features of sealed nickel cadmium batteries are required. Nickel cadmium batteries outperform lead acid batteries in dramatic ambient temperature fluctuations.

## ORDERING FORMAT

- |   |  |             |              |             |           |           |
|---|--|-------------|--------------|-------------|-----------|-----------|
|   | <b>2</b>   | <b>P12N</b> | <b>2 -CH</b> | <b>/LH3</b> | <b>-M</b> | <b>-V</b> |
|   | ①  | ②           | ③ ④          | ⑤           | ⑥         | ⑦         |
| ① | 2 .....No. of Heads (0,1,2,3)                              |             |              |             |           |           |
| ② | P12N .....Series/DC Voltage<br>(PN = 6 VDC, P12N = 12 VDC) |             |              |             |           |           |
| ③ | 2 .....Capacity Indicator<br>(See Unit Selection Chart)    |             |              |             |           |           |
| ④ | -CH .....City of Chicago Spec.                             |             |              |             |           |           |
| ⑤ | /LH3 .....Lamp Suffix*                                     |             |              |             |           |           |
| ⑥ | -M .....Standard Mist White Finish                         |             |              |             |           |           |
| ⑦ | -V .....Voltmeter (See Options)                            |             |              |             |           |           |

\* See lamp chart on p.22 alternate lamps. Do not exceed unit rating in capacity or voltage.

## ACCESSORIES (Order as separate item)

- Wire Guard (A Cabinet) .....WG2  
Wire Guard (B Cabinet) .....WG3  
Mounting Platform .....MP-PQA



## BATTERY

6 or 12-volt, long life, maintenance-free sealed nickel cadmium.

## LAMP HEADS

All metal, ELF622 heads are standard and supplied with 6 or 12-volt, 12-watt lamps as specified. DR1130 heads are optional on 12-volt units and may be 12, 20 or 35-watts.

Example:

2P12N1-CH/1130-M12 12-Watt MR16

2P12N1-CH/1130-M20 20-Watt MR16

2P12N1-CH/1130-M35 35-Watt MR16

Unit and lamp head color is pure white when MR16 lamps are ordered.

Note: Do not exceed unit rating in voltage or capacity.

## OPTIONS (Add suffix to Model No.)

- Black Housing and Heads (replace "M" by) -B  
Voltmeter.....-V\*  
Ammeter .....-A\*  
Disconnect Switch.....-DS  
Improved Diagnostics, Non-Audible ..-IDNA  
Time Delay (12 min.) .....-TD\*\*  
Tamper Proof .....-TP  
3-Wire Cord and Plug.....-3CP  
3-Wire Cord and Plug (277V) ....-3CP-277

\*Not available with IDNA.

\*\*Not required when using the IDNA option.

## DIMENSIONS

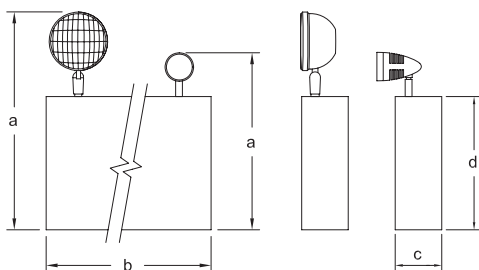

Cabinet	a	b	c	d
A	17-1/8"//14"	13"	3-5/8"	10-1/2"
B	17-1/8"//14"	16-1/8"	5-1/2"	10-1/2"

## UNIT SELECTION CHART

Volts	Model No. (Unit/ Lamp Suffix)	Cabinet	Capacity in Watts to 87-1/2% of Nominal Battery Voltage			
			1-1/2 Hrs	2 Hrs	3 Hrs	4 Hrs
6	2PN1-CH/LH3-M	A	25	20	14	10
	2P12N1-CH/LH3-M	A	50	36	25	18
12	2P12N2-CH/LHK-M	B	72	60	50	36

# SN CH Series

Industrial/Commercial Unit Equipment  
6-Volt, Nickel Cadmium Battery

The SN CH Series offers a wide variety of capacities utilizing highly-reliable wet Nickel Cadmium batteries. Able to withstand temperature fluctuations and provide extended illumination times, these units can stand alone and also drive remote emergency lights.



## APPLICATIONS

Excellent high capacity units ideal where extended unit run times may be required, and/or remote fixtures will be connected. Unit offers special advantages of the long-life nickel cadmium battery including excellent recharging capability, and superior performance over extended temperature ranges.

## ORDERING FORMAT

2 SN 4 -CH/H7553 -G -V  
① ② ③ ④ ⑤ ⑥ ⑦

- ① — **2** .....No. of Heads (0, 1, 2, 3)
- ② — **SN** .....Series
- ③ — **4** .....Capacity Indicator  
(See Unit Selection Chart)
- ④ — **-CH** .....City of Chicago Spec.
- ⑤ — **/H7553** ..Lamp Suffix\*
- ⑥ — **-G** .....Standard Gray Finish
- ⑦ — **-V** .....Voltmeter (See Options)

\* See lamp chart on p. 22 for alternate lamps.  
Do not exceed unit rating in capacity or voltage.

## ACCESSORIES (Order as separate item)

Wire Guard ..... **WG3**  
Mounting Platform ..... **MP-A**

## BATTERY

6-volt high performance wet Nickel Cadmium battery in translucent plastic cells with expected life of 13 years.

## LAMP HEADS

All metal, ELF622 heads standard with 6-volt, 12-watt lamps. See lamp data on p. 22 for alternate lamps.

Note: Do not exceed unit rating in voltage or capacity.

## OPTIONS (Add suffix to Model No.)

Voltmeter..... **-V**  
Ammeter ..... **-A**  
Disconnect Switch..... **-DS**  
Time Delay (12 min.)..... **-TD**  
Thermal Jacket (120V) ..... **-H1**  
Thermal Jacket (277V) ..... **-H2**  
3-Wire Cord & Plug ..... **-3CP**  
3-Wire Cord & Plug (277V).. **-3CP-277**



## FEATURES

- **RELIABILITY:** The SN CH Series has a three-year full warranty (excluding lamps).
- **HOUSING:** Heavy duty steel case with front access panel and gray enamel finish.
- **MOUNTING:** Conduit knockouts and rear keyhole mounting slots are provided. Mounting platform or bracket available.
- **ELECTRONICS:**
  - Automatic, temperature-compensated, pulse-type charger.
  - High capacity, automatic, dust-tight instantaneous transfer relay.
  - Labor-saving AC line latch prevents battery discharge during installation to a non-energized circuit.
  - Automatic brownout protection is provided.
  - Two separately fused output circuits.
- **CONTROLS:**
  - Red charger monitor LED indicates state of charge of the battery.
  - Amber AC-ON LED indicates AC power is on.
  - Momentary test switch allows for quick operational check of entire system.
- **POWER REQUIREMENTS:**
  - 120/277-Volt AC.

## DIMENSIONS

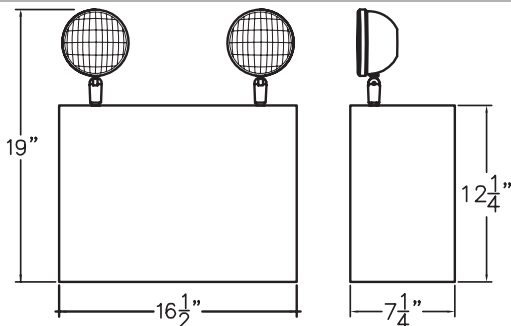

## UNIT SELECTION CHART

Volts	Cabinet	Model No. (Unit/Lamp Suffix)	Capacity in Watts to 87-1/2% of Nominal Battery Voltage			
			1-1/2 Hrs.	2 Hrs.	3 Hrs.	4 Hrs.
6	C	2SN2-CH/H7553-G	50	45	25	18
	C	2SN3-CH/H7553-G	70	60	35	25
	C	2SN4-CH/H7553-G	100	80	50	35
	C	2SN6-CH/H7553-G	130	105	70	50
	C	2SN7-CH/H7553-G	160	130	80	60

# DR1130-CH Series

Unit Heads and Matching Remote  
Emergency Lighting Fixtures

For interiors where aesthetics are a priority, the DR1130-CH Series combines contemporary styling with the ultra efficiency of MR16 halogen lamps.

## DIMENSIONS

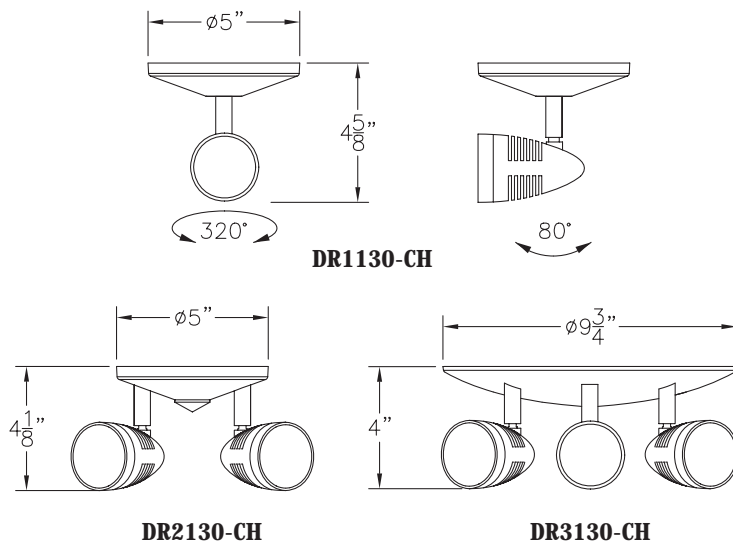

## LAMP DATA



Lamp type	Catalog Suffix	Voltage	Watts	Center Beam Candle Power
MR16	M12	12	12	400
	M20	12	20	600
	M35	12	35	1500
	M50	12	50	2200

For replacement part number, consult Lamp Chart on p. 22.

## ORDERING INFORMATION

Example: DR1130WH-20W-CH

--	--	--	--

Model

Color

Wattage

City of Chicago  
Approved

DR1130 = One Head  
DR2130 = Two Heads  
DR3130 = Three Heads

WH = White  
BK = Black

-12W = 12-Watt  
-20W = 20-Watt  
-35W = 35-Watt  
-50W = 50-Watt

-CH

# ELF622-CH Series

Unit Heads and Matching Remote  
Emergency Lighting Fixtures

A multi-purpose, surface-type remote fixture, the ELF622-CH Series is ideally suited for most commercial applications.



## DIMENSIONS

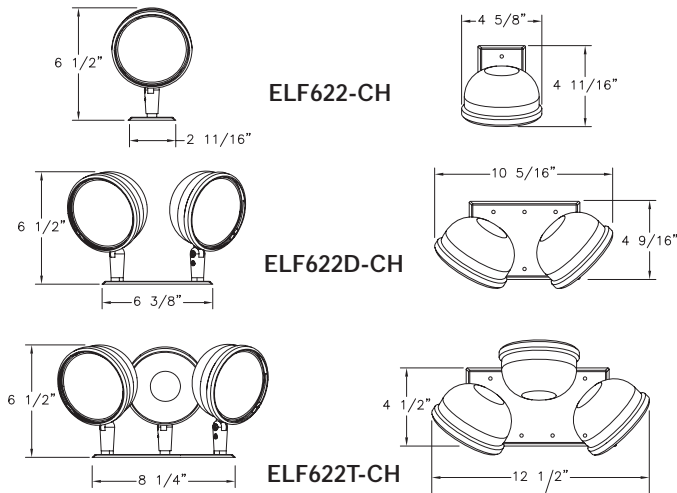

## FEATURES

- **RELIABILITY:** The ELF622-CH Series come complete with a 3-year warranty (excluding lamps).
- **UNIT DATA:** All metal construction remote head fixture with fully adjustable swivel. Available as a single, double or triple head fixture. Standard finish is chrome. Off-white or black available as an option. PAR36 sealed beam, PAR36 sealed beam halogen, and Bi-Pin halogen lamps are available.

## LAMP DATA



Lamp Type	Catalog Suffix	Voltage	Watts	Lumen
Bi-Pin Halogen	LHK	6	12	240
	LH8	6	20	402
	LH3 12	12	12	300
	LH8 12	12	20	314
PAR36 Sealed Beam Halogen	H7553	6	12	227
	H7554	6	20	382
	H7557	12	12	262
	H7616	12	37	756
PAR36 Sealed Beam	4510	6	25	385
	4515	6	30	460
	4446	12	25	395
	4406	12	35	460

For replacement part number, consult Lamp Chart on p. 22.

## ORDERING INFORMATION

Example: ELF622-CH/LHK-M6 or ELF622-CH/H7553-M

Model	City of Chicago Approved	Lamp Type	Color	Voltage
ELF622 = One Head	-CH	/LHK = 6V, 12W	Blank = Chrome	Blank = sealed beam
ELF622D = Two Heads		/H7553 = 6V, 12W	-M = Mist White	6 = 6-Volt
ELF622T = Three Heads		/LH3 = 12V, 12W	-BK = Black	12 = 12-Volt

# Lamp Data

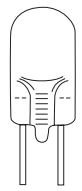
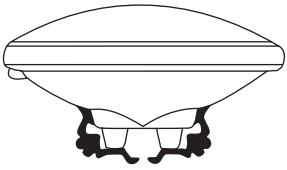
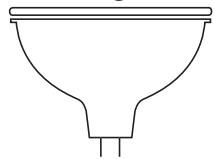
BI-PIN Halogen Lamps	Lamp Type	Catalogue Suffix	Voltage	Watts	Lumens	Replacement Parts
 <p><b>T-2 3/4</b></p>	<b>Bi-Pin Halogen</b>	LHK	6	12	420	580.0011
		LH8	6	20	402	580.0022
		LH3 12	12	12	300	580.0015
		LH8 12	12	20	314	580.0027
Sealed Beam Lamps  <p><b>PAR36</b></p>	<b>PAR36 Sealed Beam Halogen</b>	H7553	6	12	227	550.0089
		H7554	6	20	382	550.0021
		H7557	12	12	262	550.0025
		H7616	12	37	756	550.0047
	<b>PAR36 Sealed Beam</b>	4510	6	25	385	550.0017
		4515	6	30	460	550.0035
		4446	12	25	395	550.0023
		4406	12	35	460	550.0032
Halogen  <p><b>MR16</b></p>	<b>MR16</b>				<b>Center Beam Candle Power</b>	
		M12	12	12	400	580.0080
		M20	12	20	600	580.0075
		M35	12	35	1500	580.0083
		M50	12	50	2200	580.0076

# Popular Options

Lightalarms life safety equipment is available with a range of options that can be added to enhance performance, simplify testing or adapt equipment for use in specific environments. Please refer to individual product pages to verify availability of individual options on specific equipment.

## **Voltmeter**

Option provides a visual indication, in the test mode, of the unit's battery voltage. The good/check meter face allows maintenance personnel to recognize charger and battery function.

**Add Suffix: -V**

## **Ammeter**

Option provides an indication of charge current when the unit is in the equalize mode. This verifies charger capability and the current acceptance of the battery.

**Add Suffix: -A**

## **Dual Circuit**

Option provides two A.C. input circuits to permit 2 separate A.C. sources to energize the sign. Available in 120/120VAC or 277/277VAC.

**Add Suffix: -2**

## **Tamper Proof**

Tamper proof screws may be used on certain units to avoid unauthorized entry to circuitry or vandalism.

**Add Suffix: -TP**

## **Disconnect Switch**

Option will disconnect lamp load when area is not in use during prolonged power failure. The switch may also be used to reactivate emergency power to remote or built in heads.

**Add Suffix: -DS**

## **Time Delay**

Option is designed to be used in areas where mercury vapor or HID type lamps are used for normal lighting. As these lamps require several minutes to re-strike and to produce their nominal lighting output, it is necessary to also hold the emergency lighting on for this period, even after the AC utility has been restored. A time delay unit can be helpful in areas where it is difficult to directly access an emergency lighting unit's test switch. The power to the unit can be briefly switched off and on at the breaker panel, and the maintenance person can then return to the unit and observe a timed emergency operation.

**Add Suffix: -TD**

## **Remote Test Switch**

A hardwired push button test switch connected in series with the AC emergency line facilitates testing emergency lighting units that are not easily accessible.

**Add Suffix: -RTS**

## **Damp Location**

Option for environments that are subject to moderate amounts of moisture (humidity), and a temperature range between 10 and 40 degrees C. Example: partially protected exterior areas such as canopies, stairwells, etc.

**Add Suffix: -DL**

## **Thermal Jacket**

Option to be used in areas where temperature may drop below 0°C. The thermostat will activate the heating pad at 0°C and will cut off at 16°C. The heating pad is rated at 50 watts. Contact factory for temperature limitations.

**Add Suffix: -H1 (120V) -H2 (277 V)**

## **Self-Test/Diagnostic Feature (for exit signs)**

Option is designed to continuously monitor the charger assembly, battery and LED assembly current. If a fault is indicated the external service required indicator will illuminate. The diagnostic/self test will self test for 30 seconds every 30 days, 30 minutes every 60 days and 90 minutes annually. Meets NFPA 101 Life Safety Code requirements for periodic testing.

**Add Suffix: -D**

## **Improved Diagnostics/Improved Diagnostics Non-audible (ID/IDNA, for battery units)**

See page 26.





# Accessories



## Wire Guards

**Wire Guard 1**  
Catalog Number: WG1

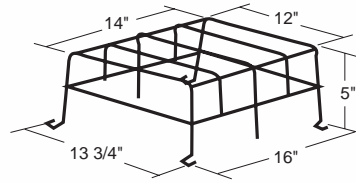

**Wire Guard 5**  
Catalog Number: WG5

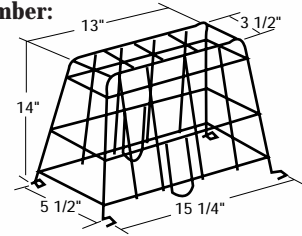

**Wire Guard 2**  
Catalog Number: WG2

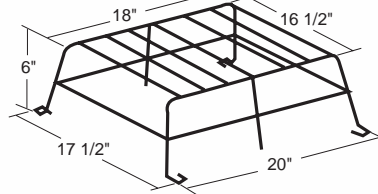

**Wire Guard 6**  
Catalog Number: WG6

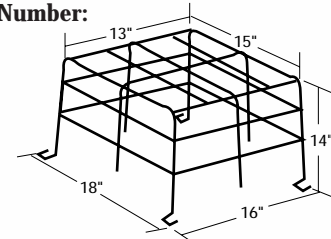

**Wire Guard 3**  
Catalog Number: WG3

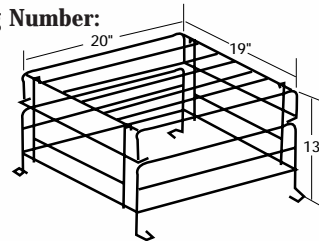

**Wire Guard 10**  
Catalog Number: WG10

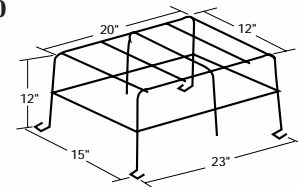

**Wire Guard 4**  
Catalog Number: WG4

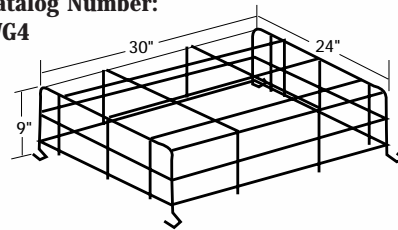

**Wire Guard 12**  
Catalog Number: WG12

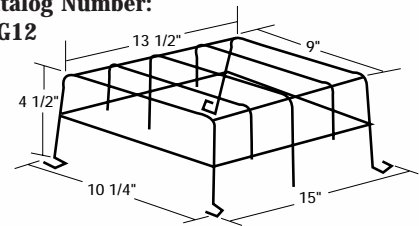

## Vandal Resistant Covers

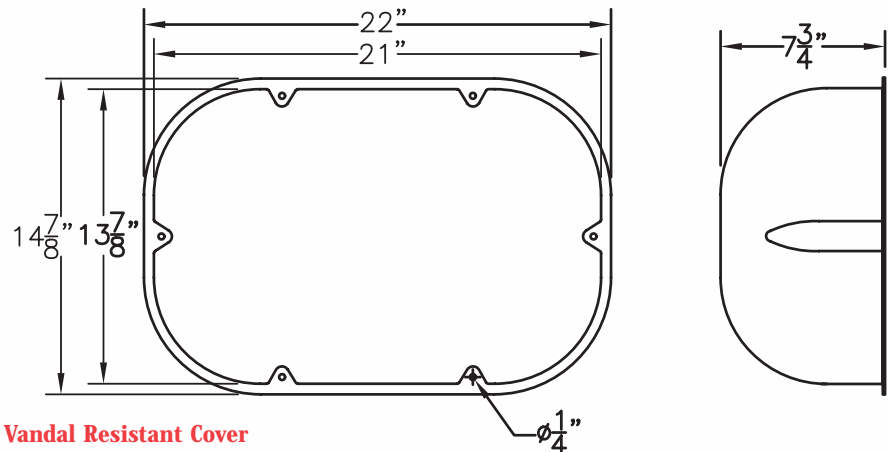

**Vandal Resistant Cover**  
Application: MG CH Series  
Catalog Number: CPS or CPS-4X (NEMA-4X)

# Accessories



- 14 gauge steel
- Corrosion resistant undercoat
- Oven baked hammertone finish
- 1/2" retaining lip on three sides
- Keyhole slots for easy mounting

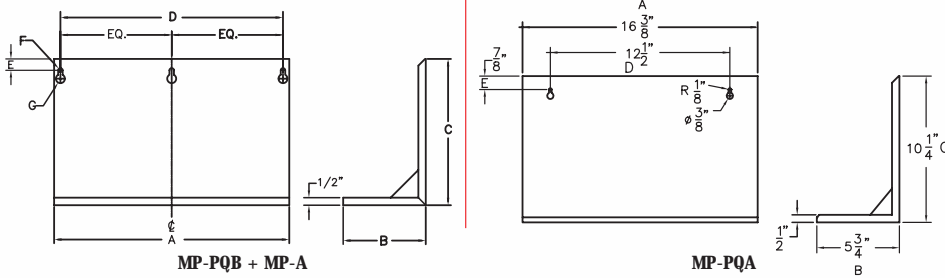

Model	Dimensions (inches)						
	A	B	C	D	E	F	G
MP-PQB & MP-A	17	7 3/4	12 1/4	16	3/4	5/16	5/8
MP-PQA	16 3/8	5 3/4	10 1/4	12 1/2	7/8	1/8	3/8

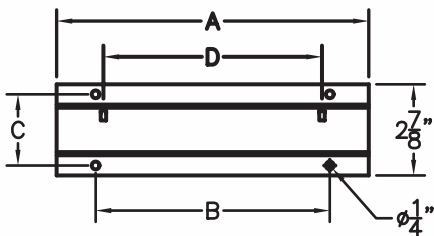

- 16 gauge steel
- Corrosion resistant undercoat
- Oven baked hammertone finish
- Supplied with rubber stand-offs for unit and machine screws to secure unit to bracket

Model	Dimensions (inches)			
	A	B	C	D
MB-A	10	7 1/2	2 3/16	7



## Mounting Platforms

## Mounting Brackets

# Improved Diagnostics

By incorporating our most popular standard diagnostics features with a powerful 8-bit microcontroller, our new Improved Diagnostics system assures unsurpassed reliability in one, totally contained system. In the event of an equipment malfunction, the improved diagnostics system produces an audible warning in the form of an intermittent beep and the LED indicator associated with the fault will illuminate continuously. When the problem is acknowledged by depressing the alarm/silence/test button, the alarm is silenced and the LED indicator changes to a flashing mode until the problem is corrected.

- Continually monitors system parameters
- Incorporates state-of-the-art microcontroller technology
- ID includes audio and visual service alarms
- IDNA non-audible version for visual service alarms only
- Self-testing in accordance with NFPA101, Life Safety Code

## FEATURES

- **BATTERY FAILURE:**  
(Red) Illuminates if the battery is shorted or battery voltage drops below preset value. Will also detect incorrect battery (ie. 6VDC vs. 12VDC)
- **BATTERY DISCONNECT:**  
(Red) Illuminates if the battery circuit is open.
- **CHARGER FAILURE:**  
(Red) Illuminates when charger is not functioning properly by monitoring the charger current.
- **LAMP FAILURE:**  
(Red) Illuminates when one or more emergency lamps burn. Also monitors remote lamps.
- **SERVICE ALARM:**  
(Red) Illuminates when a fault is detected that requires a qualified service technician.
- **AC ON:**  
(Green) Lit when line voltage is present.
- **CHARGER ON:**  
(Amber) Illuminates when charger is recharging the battery.
- **ALARM ON:**  
Button is used to acknowledge and silence alarms. Also functions as a manual test switch to simulate a power failure.
- **SELF TESTING:**  
Unit tests itself every thirty days for one minute, thirty minutes on the sixth month and ninety minutes annually.
- **TO ORDER FOR COMPATIBLE UNIT:**  
Add suffix -ID to model number  
Add suffix -IDNA (for non-audible circuit) to model number.

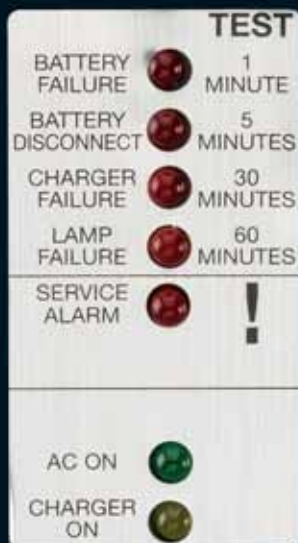

# Wiring Size Guide

## Determining Wire Size

The following information is provided to assist in designing proper emergency lighting systems effectively and economically by using a code-compliant wire size for load circuits. When remote lighting fixtures and/or exit signs are connected to emergency lighting units, circuit runs must be of sufficient size to maintain a proper operating voltage to all lamps. The National Electrical Code limits voltage to drop to a maximum of 5% of nominal. The table below gives the maximum length or wire run based on systems voltage, wire gauge and total wattage on the run. To determine the maximum length of a wire run not listed, divide the value of the load in watts into the constant listed at the bottom of each row. Example, the maximum wire run for #10 wire on a 12 volt system, with a 54 watt load, is  $3397 \div 54$  or, or 62 feet.

Conversely, to determine the maximum load on a run of known length, divide the length into the constant. Example, a 36 foot run of #12 wire on a 6 volt systems can be loaded to,  $534 \div 36$ , or 14 watts; on #10 wire, 23 watts.



Total watts on wire run	WIRING DISTANCE IN FEET (Maximum Voltage Drop 5%)												
	6 volt wire size				12 volt wire size				24 volt wire size				
	#12	#10	#8	#6	#12	#10	#8	#6	#4	#12	#10	#8	#6
6	89	141	225	357	356	566	900	1431	+	1425	+	+	+
8	66	106	168	268	267	424	675	1073	1707	1068	1698	+	+
9	59	94	150	238	237	377	600	954	1517	949	1509	+	+
10	53	84	135	214	213	339	540	859	1366	854	1358	+	+
12	44	70	112	178	178	283	450	715	1138	712	1132	1801	+
16	33	53	84	134	133	212	337	536	853	534	849	1350	+
18	29	47	75	119	118	188	300	477	758	474	754	1200	1909
24	22	35	56	89	89	141	225	357	569	356	566	900	1431
25	21	33	54	85	85	135	216	343	546	341	543	864	1374
27	19	31	50	79	79	125	200	318	505	316	503	800	1272
30	17	28	45	71	71	113	180	286	455	284	452	720	1145
36	14	23	37	59	59	94	150	238	379	237	377	600	954
42	12	20	32	51	50	80	128	204	325	203	323	514	818
45	11	18	30	47	47	75	120	190	303	189	301	480	763
48	11	17	28	44	44	70	112	178	284	178	283	450	715
50	10	16	27	42	42	67	108	171	273	170	271	432	687
75	7	11	18	28	28	45	72	114	182	113	181	288	458
100	5	8	13	21	21	33	54	85	136	85	135	216	343
150	—	5	9	14	14	22	36	57	91	56	90	144	229
200	—	—	6	10	10	16	27	42	68	42	67	108	171
250	—	—	5	8	8	13	21	34	54	34	54	86	137
300	—	—	—	7	7	11	18	28	45	28	45	72	114
400	—	—	—	5	5	8	13	21	34	21	33	54	85
500	—	—	—	—	—	6	10	17	27	17	27	43	68
Constant	534	849	1350	2148	2137	3397	5403	8590	13660	8548	13588	21613	34363

### Longer Wire Runs

The wiring distances give the maximum length of a battery circuit, assuming that the entire load is concentrated at the end of the circuit. If loads are uniformly spaced along the circuit path (equal watts, equal distances), the lengths in the table may be increased, based on number of fixtures on a given circuit, by means of the chart and formula below.

Number of Fixtures	2	3	4	5	6	N
Multiply Feet By	1.33	1.5	1.6	1.67	1.7	$12n/(n+1)$

For example, a 36 foot long, 6 volt circuit has (3) 9 watt heads spaced 12 feet apart. According to the wire run table, # 8 wire must be used (at 50 feet for a 5% voltage drop.) but, by multiplying the 31 feet for #10 wire by 1.5, a 461/2 foot wire run is acceptable, so #10 wire may be used and still meet the 5% voltage drop limitation.

**Note:** According to the National Electrical Code, Article 720-Y, the smallest permissible wire size for systems under 50 volts is the #12 wire gage.

# Life Safety Code

## SECTION 7.8 ILLUMINATION OF MEANS OF EGRESS 7.8.1 General.

**7.8.1.1\*** Illumination of means of egress shall be provided in accordance with section 7.8 for every building and structure where required in Chapters 11 through 42. For the purposes of this requirement, exit access shall include only designated stairs, aisles, corridors, ramps, escalators, and passageways leading to an exit. For the purposes of this requirement, exit discharge shall include only designated stairs, aisles, corridors, ramps, escalators, walkways, and exit passageways leading to a public way.

**7.8.1.2** Illumination of means of egress shall be continuous during the time that the conditions of occupancy require that the means of egress be available for use. Artificial lighting shall be employed at such locations and for such periods of time as required to maintain the illumination to the minimum criteria values herein specified.

*Exception: Automatic, motion sensor-type lighting switches shall be permitted within the means of egress, provided that switch controllers are equipped for fail-safe operation, illumination timers are set for a minimum 15 min duration, and the motion sensor is activated by any occupant movement in the area by the lighting units.*

**7.8.1.3\*** The floors and other walking surfaces within an exit and within the portions of the exit access and exit discharge designated by 7.8.1.1 shall be illuminated to values of not less than 1 footcandle (10 lx) measured at the floor.

*Exception No. 1: In assembly occupancies, the illumination of the floors of exit access shall be not less than 0.2 footcandle (2 lx) during periods of performances or projections involving directed light.*

*Exception No. 2\*: This requirement shall not apply where operations or processes require low lighting levels.*

**7.8.1.4\*** Required illumination shall be arranged so that the failure of any single lighting unit does not result in an illumination level of less than 0.2 footcandle (2 lux) in any designated area.

**7.8.1.5** The equipment or units installed to meet the requirements of Section 7.10 also shall be permitted to serve the function of illumination of means of egress, provided that all requirements of section 7.8 for such illumination are met.

## 7.8.2 Sources of Illumination.

**7.8.2.1** Illumination of means of egress shall be from a source of considered reliable by the authority having jurisdiction.

**7.8.2.2** Battery-operated electric lights and other types of portable lamps or lanterns shall not be used for primary illumination of means of egress. Battery-operated electric lights shall be permitted to be used as an emergency source to the extent permitted under Section 7.9

## SECTION 7.9 EMERGENCY LIGHTING 7.9.1 General.

**7.9.1.1\*** Emergency lighting facilities for means of egress shall be provided in accordance with this section 7.9 for the following: (1) Buildings or structures where required in Chapters 11 through 42. (2) Underground and windowless structures as addressed in section 11.7. (3) High-rise buildings as required by other sections of this code. (4) Doors equipped with delayed egress locks. (5) The stair shaft and vestibule of smokeproof enclosures which shall be permitted to include a standby generator that is installed for the smokeproof enclosure mechanical ventilation equipment and used for the stair shaft and vestibule emergency lighting power supply. For the purposes of this requirement, exit access shall include only designated stairs, aisles, corridors, ramps, escalators, and passageways leading to an exit. For the purposes of this requirement, exit discharge shall include only designated stairs, ramps, aisles, walkways, and escalators leading to a public way.

**7.9.1.2** Where maintenance of illumination depends on changing from one energy source to another, a delay of not more than 10 seconds shall be permitted.

## 7.9.2 Performance of System.

**7.9.2.1\*** Emergency illumination shall be provided for not less than 1 1/2 hours in the event of failure of normal lighting. Emergency lighting facilities shall be arranged to provide initial illumination that is not less than an average of 1 footcandle (10 lx) and, at any point, not less than 0.1 footcandle (1 lx) measured along the path of egress at floor level. Illumination levels shall be permitted to decline to not less than an average of 0.6 footcandle (6 lx) and, at any point, not less than 0.06 footcandle (0.6 lx) at the end of the 1 1/2 hours. A maximum-to-minimum illumination uniformity ratio of 40 to 1 shall not be exceeded.

**7.9.2.2\*** The emergency lighting system shall be arranged to provide the required illumination automatically in the event of any of the following: (1) Interruption of normal lighting such as any failure of public utility or other outside electrical power supply. (2) Opening of a circuit breaker or fuse. (3) Manual act(s), including accidental opening of a switch controlling normal lighting facilities.

**7.9.2.3** Emergency generators providing power to emergency lighting systems shall be installed, tested, and maintained in accordance with NFPA 110, Standard for Emergency and Standby Power Systems. Stored electrical energy systems where required in this Code shall be installed and tested in accordance with NFPA 111, Standard on Stored Electrical Energy Emergency and Standby Power Systems.

**7.9.2.4\*** Battery-operated emergency lights shall use only reliable types of rechargeable batteries provided with suitable facilities for maintaining them in properly charged condition. Batteries used in such lights or units shall be approved for their intended use and shall comply with NFPA 70, National Electrical Code®.

**7.9.2.5** The emergency lighting system shall be either continuously in operation or shall be capable of repeated automatic operation without manual intervention.

**7.9.3 Periodic Testing of Emergency Lighting Equipment.** A functional test shall be conducted on every required emergency lighting system at 30-day intervals for not less than 30 sec. An annual test shall be conducted for a 1-1/2 hour duration. Equipment shall be fully operational for the duration of the test. Written records of visual inspections and tests shall be kept by the owner for inspection by the authority having jurisdiction.

*Exception: Self-testing/self-diagnostic, battery-operated emergency lighting equipment that automatically performs a test of not less than 30 sec. and diagnostic routine not less than once every 30-days and indicates failure by status indicator shall be exempt from the 30-day functional test, provided that a visual inspection is performed at 30-day intervals.*

# Life Safety Code (cont'd)

## SECTION 7.10 MARKING OF MEANS OF EGRESS

### 7.10.1 General.

**7.10.1.1 Where Required.** Means of egress shall be marked in accordance with section 7.10 where required by Chapters 11 through 42.

**7.10.1.2\* Exits.** Exits, other than main exterior exit doors that obviously and clearly are identifiable as exits, shall be marked by an approved sign readily visible from any direction of exit access.

**7.10.1.3 Exit Stair Door Tactile Signage.** Tactile signage shall be located at each door into an exit stair enclosure, and such signage shall read as follows:

EXIT

Signage shall comply with CABO/ANSI A117.1, *American National Standard for Accessible and Usable Buildings and Facilities*, shall be installed adjacent to the latch side of the door 60 in. (152 cm) above the finished floor to the centerline of the sign.

*Exception: This requirement shall not apply to existing buildings, provided the occupancy classification does not change.*

**7.10.1.4\* Exit Access.** Access to exits shall be marked by approved, readily visible signs in all cases where the exit or way to reach it is not readily apparent to the occupants. Sign placement shall be such that no point in the exit access corridor is in access of 100 ft (30 m) from the nearest externally illuminated sign and is not in access of the marked rating for internally illuminated signs.

*Exception: Signs in exit access corridors in existing buildings shall not be required to meet the placement distance requirements.*

**7.10.1.5\* Floor Proximity Exit Signs.** Where floor proximity exit signs are required by Chapters 11 through 42, signs shall be placed near the floor level in addition to those signs required for doors or corridors. These signs shall be illuminated in accordance with 7.10.5. Externally illuminated signs shall be sized and in accordance with 7.10.6.1. The bottom of the sign shall be not less than 6 in. (15.2 cm) but not more than 8 in. (20.3 cm) above the floor. For exit doors, the sign shall be mounted on the door or adjacent to the door with the closest edge of the sign within 4 in. (10.2 cm) of the door frame.

**7.10.1.6\* Floor Proximity Egress Path Marking.** Where floor proximity egress path marking is required in Chapters 11 through 42, a listed and approved floor proximity egress path marking system that is internally illuminated shall be installed within 8 in. (20.3 cm) of the floor. The system shall provide a visible delineation of the path of travel along the designated exit access and shall be essentially continuous, except as interrupted by doorways, hallways, corridors, or other such architectural features. The system shall operate continuously or at any time the building fire alarm system is activated. The activation, duration, and continuity of operation of the system shall be in accordance with 7.9.2.

**7.10.1.7\* Visibility.** Every sign required by Section 7.10 shall be located and of such size, distinctive color, and design that it is readily visible and shall provide contrast with decorations, interior finish, or other signs. No decorations, furnishings, or equipment that impairs visibility of an exit sign shall be permitted. No brightly illuminated sign (for other than exit purposes), display, or object in or near the line of vision of the required exit sign that could detract attention from the exit sign shall be permitted.

**7.10.2\* Directional Signs.** A sign complying with 7.10.3 with a directional indicator showing the direction of travel shall be placed in every location where the direction of travel to reach the nearest exit is not apparent.

**7.10.3\* Sign Legend.** Sign required by 7.10.1 and 7.10.2 shall have the word EXIT or other appropriate wording in plainly legible letters.

**7.10.4\* Power Source.** Where emergency lighting facilities are required by the applicable provisions of Chapters 11 through 42 for individual occupancies, the signs, other than approved self-luminous signs, shall be illuminated by the emergency lighting facilities. The level of illumination of the exit sign shall be in accordance with 7.10.6.3 or 7.10.7 for the required emergency lighting duration as specified in 7.9.2.1. However, the level of illumination shall be permitted to decline to 60 percent at the end of the emergency lighting duration.

### 7.10.5 Illumination of Signs.

**7.10.5.1\* General.** Every sign required by 7.10.1.2 or 7.10.1.4, other than where operations or processes require low lighting levels, shall be suitably illuminated by a reliable light source. Externally and internally illuminated signs shall be legible in both the normal end emergency lighting mode.

**7.10.5.2\* Continuous Illumination.** Every sign required to be illuminated by 7.10.6.3 and 7.10.7 shall be continuously illuminated as required under the provisions of section 7.8.

*Exception:\* Illumination for signs shall be permitted to flash on an and off upon activation of the fire alarm systems.*

### 7.10.6 Externally Illuminated Signs.

**7.10.6.1\* Size of Signs.** Externally illuminated signs required by 7.10.1 and 7.10.2, other than approved existing signs, shall have the word EXIT or other appropriate wording in plainly legible letters not less than 3/4 in. (1.9 cm) wide. The word EXIT shall have letters of a width not less than 2 in. (5 cm), except the letter I, and the minimum spacing between letters shall be not less than 3/8 in. (1 cm). Signs larger than the minimum established in this paragraph shall have letter widths, strokes, and spacing in proportion to their height.

*Exception No. 1: This requirement shall not apply to existing signs having the required wording in plainly legible letters not less than 4 in. (10.2 cm) high.*

*Exception No. 2: This requirement shall not apply to marking required by 7.10.1.3 and 7.10.1.5.*

**7.10.6.2\* Size and Location of Directional Indicator.** The directional indicator shall be located outside of the EXIT legend, not less than 3/8 in. (1 cm) from any letter. The directional indicator shall be of a chevron type as shown in Figure 7.10.6.2. The directional indicator shall be identifiable as a directional indicator at a distance of 40 ft (12.2 m). A directional indicator larger than the minimum established in this paragraph shall be proportionately increased in height, width, and stroke. The directional indicator shall be located at the end of the sign for the direction indicated.

*Exception: This requirement shall not apply to approved existing signs.*



# Life Safety Code (cont'd)

Figure 7.10.6.2 Chevron type indicator.



**7.10.6.3\* Level of Illumination.** Externally illuminated signs shall be illuminated by not less than 5ft-candles (54 lux) at the illuminated surface and shall have a contrast ratio of not less than 0.5.

#### 7.10.7 Internally Illuminated Signs.

**7.10.7.1 Listing.** Internally illuminated signs, other than approved existing signs, or existing signs, or existing signs having the required wording in legible letters not less than 4 in. (10.2 cm) high, shall be listed in accordance with UL 924, Standard for Safety Emergency Lighting and Power Equipment.

*Exception: This requirement shall not apply to signs that are in accordance with 7.10.1.3 and 7.10.1.5.*

**7.10.7.2 Photoluminescent Signs.** The face of a photoluminescent sign shall be continually illuminated while the building is occupied. The illumination levels on the face of the photoluminescent sign shall be in accordance with its listing. The charging illumination shall be a reliable light source as determined by the authority having jurisdiction. The charging light source shall be of a type specified in the product markings.

#### 7.10.8 Special Signs.

**7.10.8.1 No Exit.** Any door, passage, or stairway that is neither an exit nor a way of exit access and that is located or arranged so that it is likely to be mistaken for an exit shall be identified by a sign that reads as follows.

**NO EXIT**

Such sign shall have the word NO in letters 2 in. (5 cm) high with a stroke width of 3/8 in. (1 cm) and the word EXIT in letters 1 in. (2.5 cm) high, with the word EXIT below the word NO.

*Exception: This requirement shall not apply to approved existing signs.*

**7.10.9 Elevator Signs.** Elevators that are a part of a means of egress (see 7.2.13.1) shall have the following signs, with minimum letter height of 5/8 in. (1.6 cm), in every elevator lobby:

- (a)\* Signs that indicate that the elevator can be used for egress including any restrictions on use
- (b)\* Signs that indicate the operational status of elevators.

#### 7.10.9 Testing and Maintenance.

**7.10.9.1 Inspection.** Exit signs shall be visually inspected for operation of the illumination sources at intervals not to exceed 30 days.

**7.10.9.2 Testing.** Exit signs connected to or provided with a battery-operated emergency illumination source, where required in 7.10.4, shall be tested and maintained in accordance with 7.9.3.

Life Safety Code® 2000

Life Safety Code® and NFPA 101® are registered trademarks of the National Fire Protection Association, Inc.

# Terms and Conditions

## **TERMS:**

Terms for domestic shipments are net 30 days, subject to established credit.

## **ORDERS:**

All orders must be in writing and become effective only when accepted and acknowledged by our office.

## **MINIMUM ORDERS:**

Standard orders - \$75 per order, per shipment. Replacement parts (Batteries, PC Boards, Transformers, Lamps) - \$25 per order, per shipment.

## **PRICES:**

Prices listed on all price lists are subject to change without notice. All prices and quotations are FOB factory, Dorval, Quebec, Canada.

## **DELIVERIES:**

All delivery dates quoted are an approximation unless stated otherwise. Inventory is offered on a first-come, first served basis. Lightalarms will make every effort to accommodate customer's delivery requirements; however, in no event shall Lightalarms be held responsible for factors which are beyond its control.

## **TAXES:**

Federal excise tax, state or local taxes, if any, must be added to prices.

## **SHIPMENTS:**

All shipments are FOB factory or point of shipment. Freight charges are prepaid on all shipments within the Continental USA, and added as a separate item on the invoice. Shipments to Alaska and Hawaii are prepaid to West Coast and added to invoice, collect beyond. Freight charges are prepaid and allowed on all shipments within the Continental USA (except for AC Standby Systems), of \$1,000.00 net minimum shipped to one location at one time. Qualified shipments will be prepaid and allowed via least expensive surface route. Our responsibility ceases when materials are received for "in good condition" by the carrier. We will, however, render all possible assistance in securing satisfactory adjustment of claims. Any discrepancies in shipments must be reported in writing to the factory within 24 hours of receipt of the shipment.

## **RETURNS:**

No return material will be accepted without written factory authorization. A Returned Goods Authorization (RGA) must be requested from the factory prior to the return of any equipment. RGA must be requested within 90 days from date of shipment, except for defective products. Returned goods must be received at the factory within 30 days of issuance of RGA, with transportation charges prepaid. All goods, must be properly packed. Wet batteries must be shipped in a separate carton from units and palletized. Most currently catalogued emergency lighting battery units and fixtures in factory sealed cartons may be returned for full credit less a restocking charge. Special or made-to-order equipment is not refundable.

**SEE LIMITED WARRANTY FOR COMPLETE RETURNS POLICY**





# Limited Warranty

- 1.0 **Lightalarms 6, 12 and 24 volt Emergency Lighting Unit Equipment** (excluding lamps and fuses) are fully warranted to be free of defects in material and workmanship under normal use for a period of three years from date of installation (see Paragraph 2.0).
- 1.1 **Lightalarms 6, 12 and 24 volt Unit Equipment Batteries** are warranted as follows (Warrant below includes the 3-year full warranty on entire unit as called out in Paragraph 1.0).
- 1.2 **Lightalarms 4 volt Emergency Lighting Unit Equipment** (excluding lamps, and fuses) is fully warranted to be free of defects in material and workmanship under normal use for a period of one year from date of installation (see Paragraph 2.0).

BATTERY TYPE	LIFE EXPECTANCY	SHELF LIFE*	FULL WARRANTY	PRO RATA WARRANTY
Sealed Lead Calcium	5 years	6 months	3 years	3 years
Sealed Lead Calcium (Immobilized Electrolyte)	10 years	6 months	5 years	5 years
Sealed Long Life Lead	10 years	6 months	5 years	5 years
Sealed Nickel Cadmium	8 years	1 year	5 years	5 years
Refillable Lead Calcium	10 years	6 months	5 years	5 years
Refillable Nickel Cadmium	13 years	2 years	5 years	8 years

**\*MAXIMUM STORAGE LIFE. MUST BE RECHARGED IF NOT PLACED IN SERVICE OR BATTERY WARRANTY VOID**

- 2.0 The full warranty period begins on the date of installation or 90 days from date of shipment, whichever date is earlier.
- 2.1 Should a defect appear in the equipment or batteries listed in Paragraphs 1.0, 1.1 or 1.2 above within the specified full warranty period, Lightalarms will repair or replace equipment without charge (see Paragraph 3.3). Such repair or replacement shall be the purchaser's exclusive remedy.
- 2.2 The Pro Rata Warranty Period for batteries begins on the date the full warranty period ends.
- 2.3 A battery determined to be defective during the Pro Rata Warranty Period shall be repaired or replaced at a cost equal to the net price in effect at the time, reduced by the percentage obtained in multiplying 10% by the number of full years remaining in the total warranty period. Such repair or replacement at this adjusted price shall be the purchaser's exclusive remedy.
- 3.0 All warranties are subject to proper installation and maintenance in accordance with the instructions supplied.
- 3.1 Any material deemed defective must be returned, freight prepaid, to the factory for evaluation (see Paragraph 5.0-5.3). Any changes in circuitry or components by other than authorized Lightalarms personnel or its service companies will void the warranty.
- 3.2 All warranties are limited to the repair and/or replacement of parts or equipment, which, upon examination at our plant, are determined to be defective and in our judgement are subject to repair or replacement under warranty. Replacement of lamps and fuses is not included in the warranty.
- 3.3 If new replacement parts are shipped before defective goods are received for evaluation, the replacement parts will be invoiced at the net price in effect at that time. These charges will be credited if, upon receipt and evaluation of goods, a defect is determined. Only replacement parts will be shipped under these circumstances, if field replacement is possible. **Lightalarms FACTORY ONLY RESERVES THE RIGHT TO SHIP NEW UNIT EQUIPMENT FOR REPLACEMENT PURPOSES.** Units returned after installation cannot be restored to 100% saleable condition.
- 4.0 In no event shall Lightalarms be liable for backcharges of any kind, including, without limitation, labor charges for field repair or late penalties.
- 4.1 This warranty does not cover damages caused by improper maintenance of installation or damage due to installation in areas with other than normal temperatures and environmental conditions per application specifications. Lightalarms assumes no responsibility for any damage to people, property, apparatus or otherwise resulting from improper installation or maintenance of its Emergency Lighting Unit Equipment.
- 4.2 This warranty does not cover damages caused by abuse, fire or Act of God.
- 4.3 In no event shall Lightalarms be liable for incidental or consequential damages.
- 4.4 The foregoing warranty is in lieu of all other warranties, expressed or implied, or merchantability, fitness for a particular purpose or any other thing. Except as stated in this warranty, Lightalarms shall not be liable for any defects in, or breach of any contract relating to, the quality of performance of Lightalarms Equipment under any theory of law including, without limitation, contract, negligence, strict liability or misrepresentation.
- 4.5 Lightalarms warranty coverage shall not apply to any equipment of another manufacturer used in conjunction with Lightalarms Equipment.
- 4.6 Some states do not allow limitation on how long an implied warranty lasts, so the above limitation may not apply to you. Some states do not allow the exclusion or limitation of incidental or consequential damages, so the above limitation or exclusion may not apply to you. This written warranty gives you specific legal rights and you may also have other rights which vary from state to state.
- 5.0 No returned defective materials will be accepted without a Returned Goods Authorization issued in writing by an authorized Lightalarms employee.
- 5.1 Purchaser is responsible for secure packing of returned materials to provide best possible assurance against damage in shipment.
- 5.2 Defective batteries of any kind must not be returned to Lightalarms's factory without strict adherence to special instructions for handling and shipping. **WARNING** Never ship a refillable wet battery in any type of emergency lighting equipment. Failure to adhere to this policy will void warranty.
- 5.3 Defective goods returned to the factory must be shipped prepaid. **COLLECT RETURNED SHIPMENT WILL BE REFUSED.** Freight charges to return repaired equipment or ship replacement equipment to the purchaser to be paid by Lightalarms. Factory will return repaired goods via same shipping method as received.

**FAILURE TO COMPLY WITH ANY OF THE STIPULATIONS SET FORTH WILL VOID THE WARRANTY.**

**ANY EXCEPTIONS TO THE FOREGOING WARRANTY MUST BE REQUESTED AND ACCEPTED IN WRITING PRIOR TO SHIPMENT.**

**LIGHTALARMS EQUIPMENT NOT LISTED IN PARAGRAPHS 1.0, 1.1 OR 1.2 IS WARRANTED AS DESCRIBED**

**ON ITS INDIVIDUAL DATA SHEET WITH THE STIPULATIONS AS STATED IN PARAGRAPHS 2.0-5.3.**